

Replacement Procedure Rotary Actuators Air Grippers

Rotary Actuators

CRA1	Rotary Actuator/Rack & Pinion Type	p. 513
CRQ2	Compact Rotary Actuator/Rack & Pinion Type	p. 516
CRQ2X	Low-Speed Compact Rotary Actuator/Rack & Pinion Type	p. 516
MSQ	Rotary Table/Rack & Pinion Type	p. 521

Air Grippers

JMHZ2	Parallel Style Air Gripper/Compact Type	p. 525
MHZ2	Parallel Type Air Gripper/Standard Type	p. 527
MHZL2	Parallel Type Air Gripper/Long Stroke Type	p. 527
MHZJ2	Parallel Type Air Gripper/With Dust Cover	p. 527
MHF2	Low Profile Air Gripper	p. 532
MHL2-Z	Parallel Style Air Gripper/Wide Type	p. 534
MHL2	Parallel Type Air Gripper/Wide Type	p. 534
MHR3/MDHR3	Rotary Actuated Air Gripper/3-Finger Type	p. 535
MHK2	Wedge Cam Operation Slide Guide/Air Gripper/2-Finger Type	p. 536
MHS2/MHS3/MHS4	Parallel Type Air Gripper/2 Finger, 3 Finger, 4 Finger	p. 537
MHSJ3	Parallel Type Air Gripper/3-Finger Type with Dust Cover	p. 539
MHSH3/MHSHJ3	Parallel Type Air Gripper/3-Finger Type Through-hole Type	p. 541
MHSL3	Parallel Type Air Gripper/3-Finger Type Long Stroke	p. 545
MHC2	Angular Type Air Gripper/Standard Type	p. 547
MHY2	180° Angular Type Air Gripper Cam Type	p. 549

Actuators

Rotary Actuators
Air Grippers

Modular F.R.L.
Pressure Control Equipment

Air Preparation
Equipment

Industrial Filters

Replacement
Procedure

Actuators

Rotary Actuators
Air Grippers

Modular F.R.L.
Pressure Control Equipment

Air Preparation Equipment
Industrial Filters

CRA1 Series Replacement Procedure for Seals 1

Size 30

1. Disassembly

- 1-1. Loosen the hexagon nut ⑱ to remove the hexagon socket set screw ⑧ with the hexagon nut from the body ①.
- 1-2. Loosen the cross recessed round head tapping screw ⑰ to remove the bearing retainer ⑩ with the shaft ⑤ from the body. Remove the lower bearing ⑭ from the body housing at this time.
- 1-3. Loosen the hexagon socket head cap screw with washers ⑮ to remove the cover ② and ③ from the body. (Remove the cover from the right and left sides.)
- 1-4. Remove the piston ④ with the rack ⑥ from the body.
(The rack has a specified mounting direction, so this should be checked when removing it from the body.)

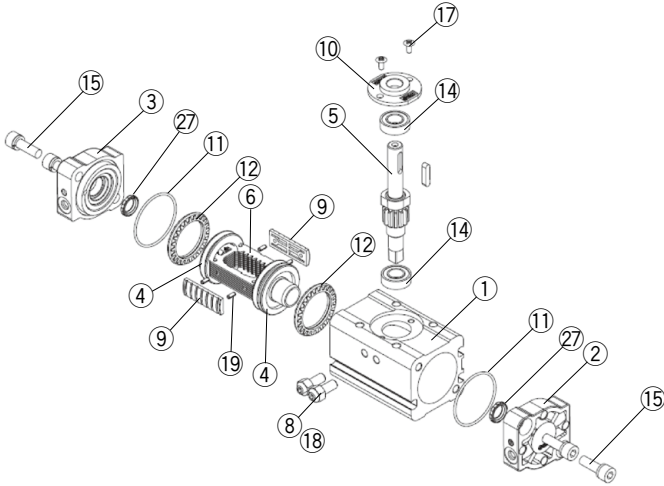

2. Assembly

- 2-1. Apply the grease provided in the seal kit to parts shown in Table 1.
- 2-2. Mount the tube gasket ⑪ to the left cover ③ to mount to the body ①. Tighten them with the hexagon socket head cap screw with washers ⑮.
- 2-3. Insert the rack ⑥ and the piston ④ into the body. Set the lower bearing ⑭ to the housing in the body. At this time, the piston assembly should be inserted carefully so as not to damage the piston seal ⑫ through which the housing for the bearing of the body will pass.
- 2-4. After push the rack and the piston until it touches the left cover, mount the shaft ⑤ to the body. Refer to Fig.1 for the direction of the keyway (facing to the right cover ②).
- 2-5. Mount the upper bearing ⑭ and the bearing retainer ⑩ to the shaft and the body. Tighten them with the cross recessed round head tapping screw ⑰.
- 2-6. Mount the tube gasket to the right cover to mount to the body. Tighten them with the hexagon socket head cap screw with washers.
- 2-7. Mount the hexagon socket set screw to the body and secure with the hexagon nut.
- 2-8. After assembly is completed, perform an operation test and check that there is no air leakage.

Table 1 Parts where grease is to be applied

Application of grease	Grease
① Body (Inner sliding surface)	GR-S-10
④ Piston (Seal groove)	
⑨ Slider (Sliding surface)	
⑪ Tube gasket	
⑫ Piston seal	
⑰ Cushion seal (For with air cushion)	

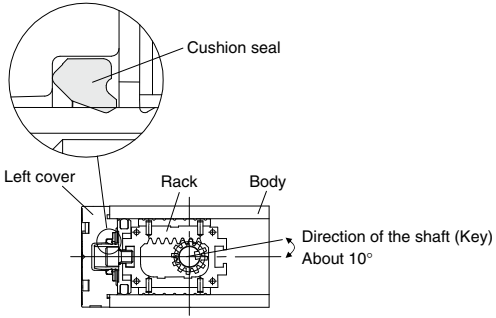

Fig.1 Direction of the assembly of the shaft seal

CRA1 Series Replacement Procedure for Seals 2

Size 50 to 100

1. Disassembly

- 1-1. Loosen the cross recessed round head tapping screw **17** to remove the bearing retainer **10** with the shaft **5** from the body **1**. Remove the lower bearing **14** from the body housing at this time.
- 1-2. Loosen the hexagon socket head cap screw with washers **15** to remove the cover **2** and **3** from the body. (Remove the cover from the right and left sides.)
- 1-3. Remove the piston **4** with the rack **6** from the body.
(The rack has a specified mounting direction, so this should be checked when removing it from the body.)

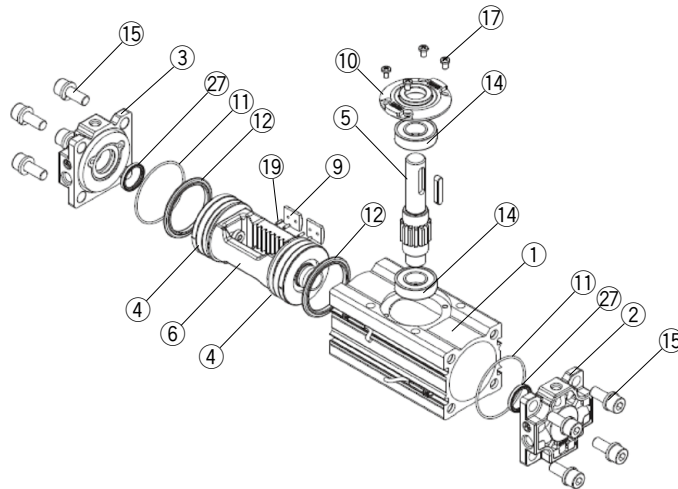

2. Assembly

- 2-1. Apply the grease provided in the seal kit to parts shown in Table 2.
- 2-2. Mount the tube gasket **11** to the left cover **3** to mount to the body **1**. Tighten them with the hexagon socket head cap screw with washers **15**.
- 2-3. Insert the rack **6** and the piston **4** into the body. Set the lower bearing **14** to the housing in the body. At this time, the piston assembly should be inserted carefully so as not to damage the piston seal **12** through which the housing for the bearing of the body will pass.
- 2-4. Push the rack and the piston until it touches the left cover. Mount the shaft **5** to the body. Refer to Fig. 2 for the direction of the keyway (facing to the right cover **2**).
- 2-5. Mount the upper bearing **14** and the bearing retainer **10** to the shaft and the body. Tighten them with the cross recessed round head tapping screw **17**.
- 2-6. Mount the tube gasket to the right cover to mount to the body. Tighten them with the hexagon socket head cap screw with washers.
- 2-7. After assembly is completed, perform an operation test and check that there is no air leakage.

Table 2 Parts where grease is to be applied

Application of grease	Grease
① Body (Inner sliding surface)	GR-S-10
④ Piston (Seal groove)	
⑨ Slider (Sliding surface)	
⑪ Tube gasket	
⑫ Piston seal	
⑰ Cushion seal (For with air cushion)	

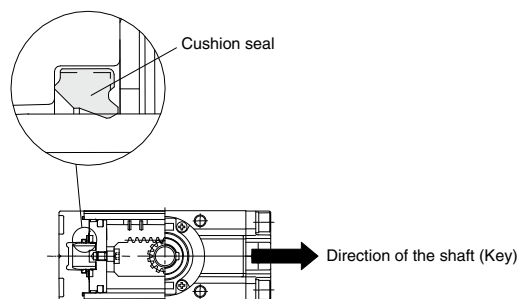

Fig. 2 Direction of the assembly of the shaft

CRA1 Series Replacement Procedure for Seals 3

Angle adjustable type

1. Disassembly

- 1-1. Loosen the cross recessed round head tapping screw ⑰ to remove the bearing retainer ⑩ with the shaft ⑤ from the body ①. Remove the lower bearing ⑭ from the body housing at this time.
- 1-2. Loosen the hexagon socket head cap screw with washers ⑮ to remove the cover ③ and ⑳ from the body. (Remove the cover from the right and left sides.)
- 1-3. Remove the piston ④ and ㉓ with the rack ⑥ from the body.
(The rack has a specified mounting direction, so this should be checked when removing it from the body.)
- 1-4. Loosen the hexagon nut ㉑ of right cover ㉒ to remove the seal washer ㉔ and hexagon nut with the hexagon socket set screw ㉖ from the angle adjustment collar ㉘.

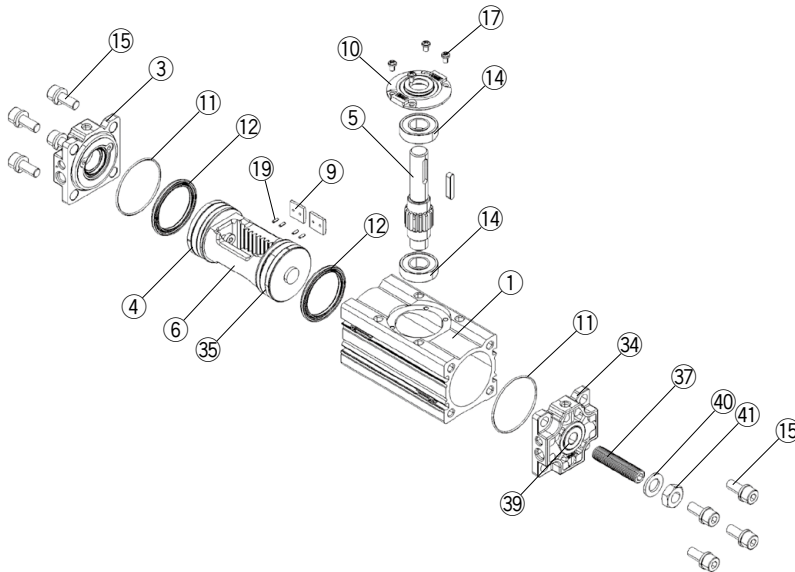

2. Assembly

- 2-1. Apply the grease provided in the seal kit to parts shown in Table 3.
- 2-2. Mount the tube gasket ⑪ to the left cover ③ to mount to the body ①. Tighten them with the hexagon socket head cap screw with washers ⑮.
- 2-3. Insert the rack ⑥ and the piston ④ and ㉓ into the body. Set the lower bearing ⑭ to the housing in the body. At this time, the piston assembly should be inserted carefully so as not to damage the piston seal ⑫ through which the housing for the bearing of the body will pass.
- 2-4. Push the rack and the piston until it touches the left cover. Mount the shaft ⑤ to the body. Refer to Fig. 3 for the direction of the keyway (facing to the right cover ㉒).
- 2-5. Mount the upper bearing ⑭ and the bearing retainer ⑩ to the shaft and the body. Tighten them with the cross recessed round head tapping screw ⑰.
- 2-6. Mount the seal washer ㉔ and the hexagon nut ㉑ to the hexagon socket set screw ㉖ to mount the angle adjustment collar ㉘ of the right cover.
- 2-7. Mount the tube gasket to the right cover to mount to the body. Tighten them with the hexagon socket head cap screw with washers.
- 2-8. After assembly is completed, perform an operation test and check that there is no air leakage.

Table 3 Parts where grease is to be applied

Application of grease	Grease
① Body (Inner sliding surface)	GR-S-10
④ ㉓ Piston (Seal groove)	
⑨ Slider (Sliding surface)	
⑪ Tube gasket	
⑫ Piston seal	
㉔ Seal washer	

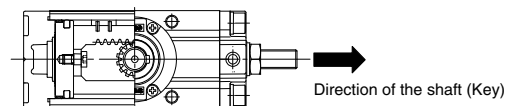

Fig. 3 Direction of the assembly of the shaft

CRQ2/CRQ2X Series Replacement Procedure for Seals 1

1. Disassembly

- 1-1. Loosen the cross recessed no.0 screw (size 10,15) or roundhead screw (size 20, 30, 40).
- 1-2. Pull out the bearing retainer and the shaft from the body. Remove the bearing from the housing at this time.
- 1-3. Loosen the hexagon socket head bolt to remove the cover assembly and the end cover assembly.
- 1-4. Push the piston assembly from one side to pull out the 2 piston assemblies from the body.
- 1-5. Take out the bearing from the body.

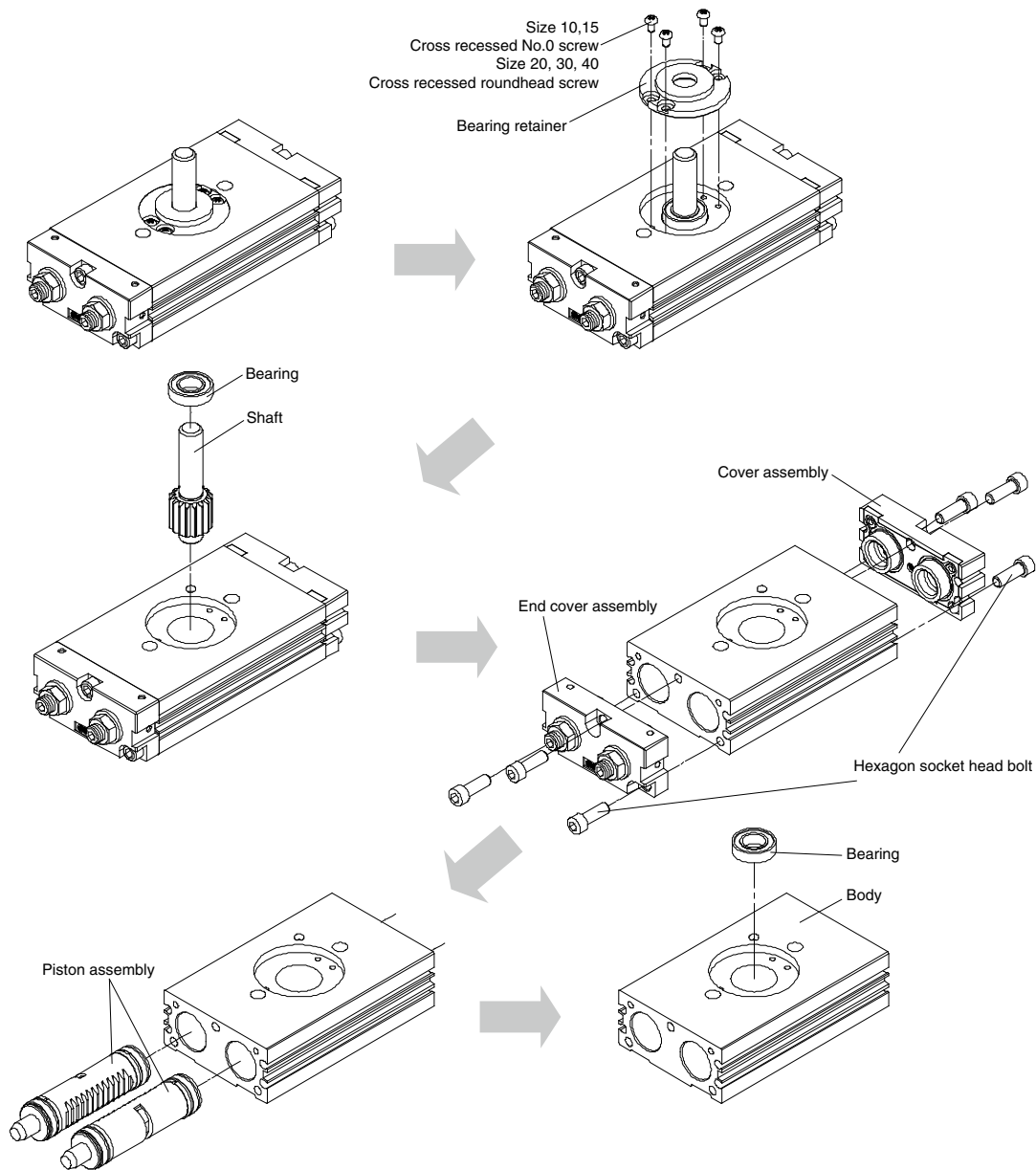

Fig.1

CRQ2/CRQ2X Series Replacement Procedure for Seals 2

2. Assembly

2-1. Clean each component sufficiently before assembled to prevent a dust from attaching.

Apply the grease which is enclosed to the seal set to each part shown in Table 1. The referential amount of applied grease is to the extent which can brighten the surface of components.

After that, mount a piston seal to the piston with care not to damage the piston seal.

Table 1 Parts applied with grease

Grease applied parts	Grease	
	CRQ2	CRQ2X
Cylinder internal surface	GR-S-010 (Lithium mineral oil grease No.2)	P523010-21
Piston seal groove		
Piston seal		
Cover gasket		
End cover gasket		
Gasket		
Cushion seal		

Body assembly

Wipe off the internal face of the cylinder body with alcohol, apply grease, and set the bearing to the housing of the body.

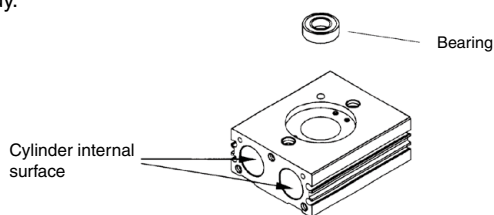

Fig.2

Piston assembly

Pay attention to the orientation of the piston seal.

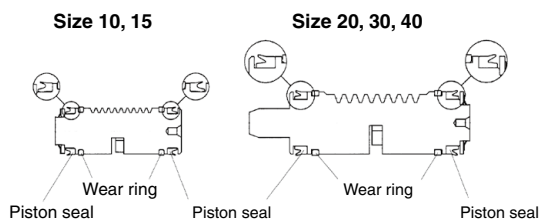

Fig.3

Cover assembly

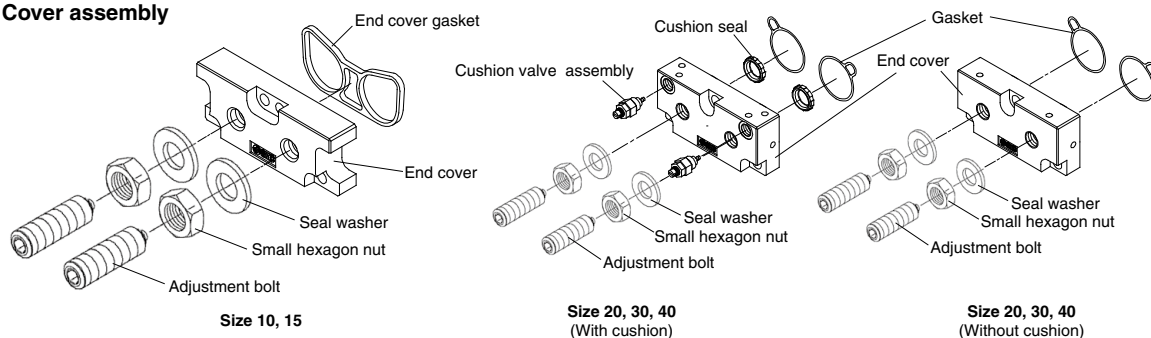

Fig. 4

Insert and attach the cushion seal and the seal with the direction in the drawing below.

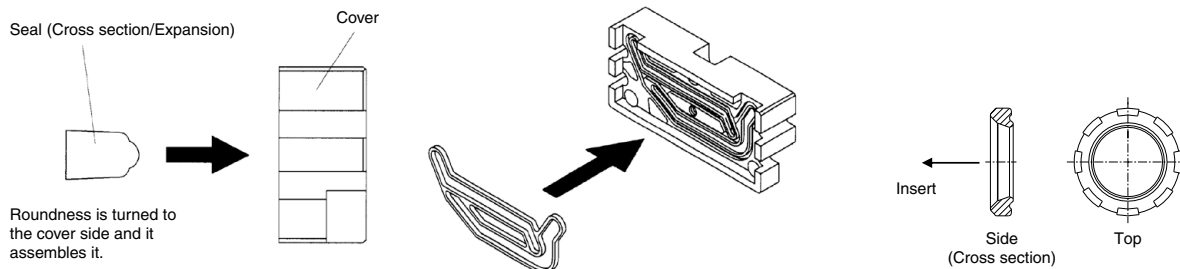

Fig.5

CRQ2/CRQ2X Series Replacement Procedure for Seals 3

Adjustment bolt assembly

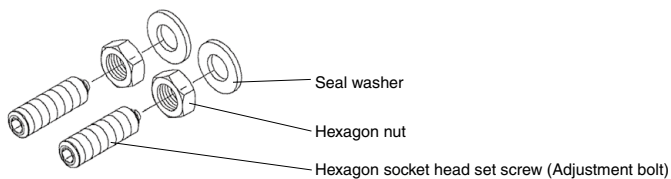
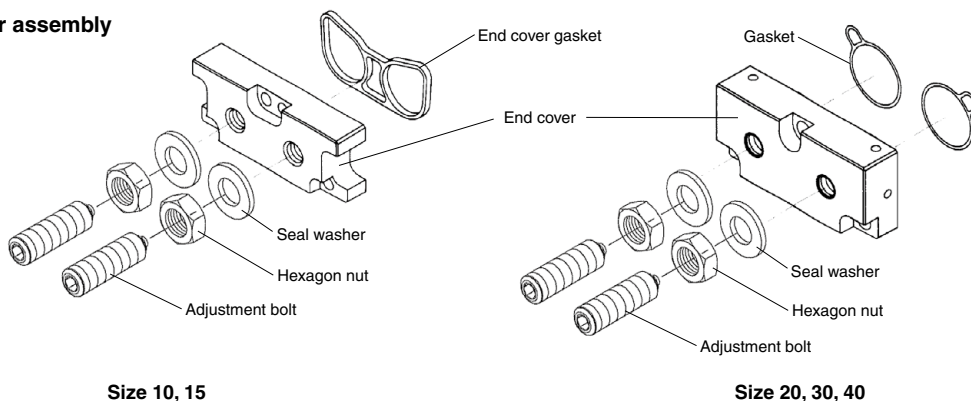

Fig. 6

End cover assembly



Size 10, 15

Size 20, 30, 40

Fig. 7

2-2. Insert the piston assembly to the body. At this time, the piston seal passes the opening of the cylinder and should be pressed inward not to be scratched. Also, pay attention to the mounting orientation of the piston. (See Fig. 8)

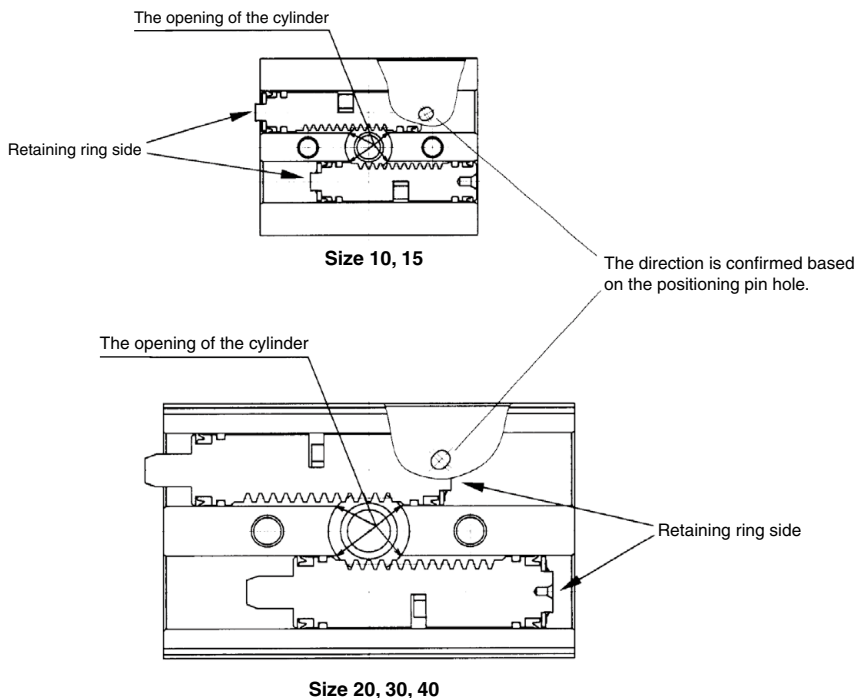

Size 10, 15

Size 20, 30, 40

Fig. 8

Actuators
 Rotary Actuators
 Air Grippers
 Modular F.R.L.
 Pressure Control Equipment
 Air Preparation
 Equipment
 Industrial Filters
 Replacement
 Procedure
 Actuators
 Rotary Actuators
 Air Grippers
 Modular F.R.L.
 Pressure Control Equipment
 Air Preparation Equipment
 Industrial Filters

CRQ2/CRQ2X Series Replacement Procedure for Seals 4

2-3. Mount the shaft and bearing to the body. The shaft should be mounted by positioning the piston assembly with reference to the flat of the shaft (size 10 and 15) and key (size 20, 30 and 40).

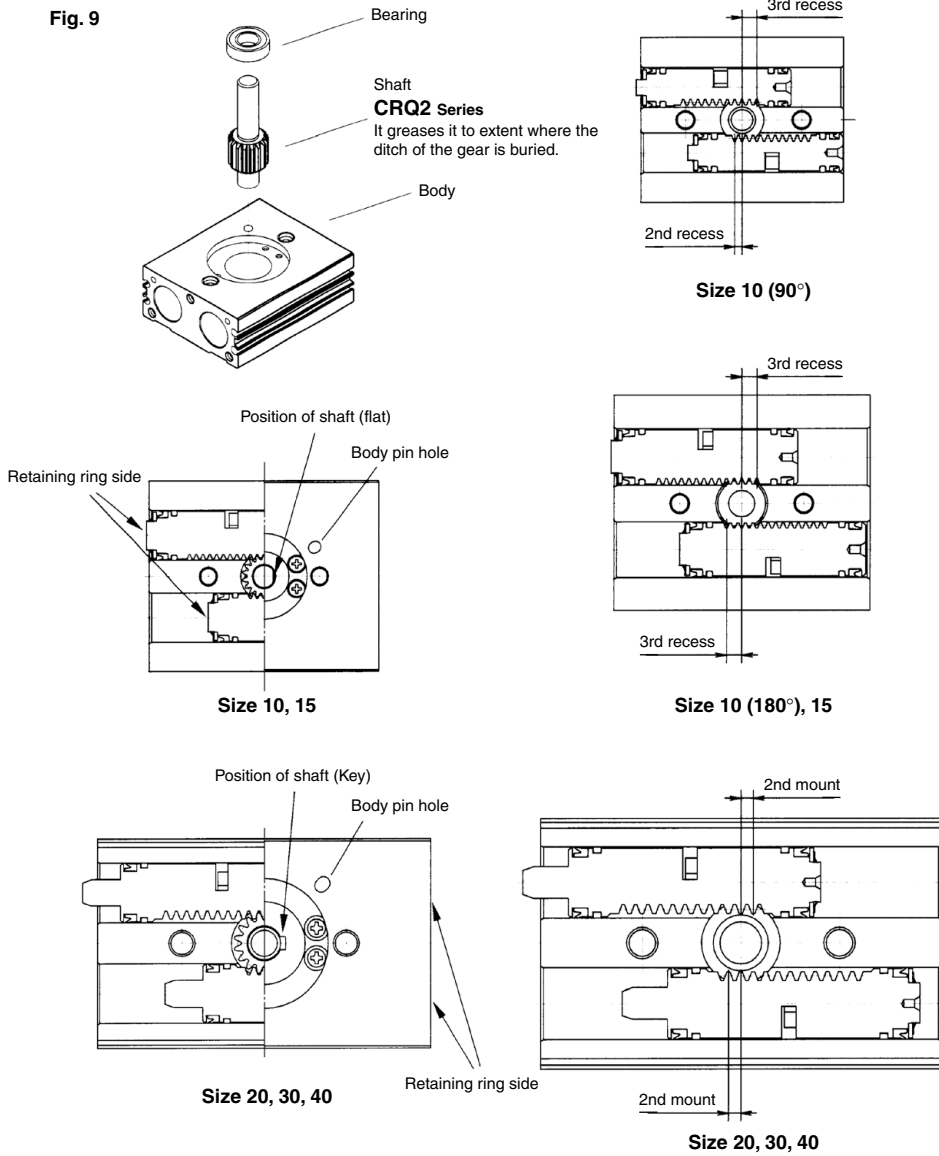

CRQ2 Series

Mount the cover and the end cover, and push the piston assembly and the cover until they touch the end cover as in Fig.10. Adjust the hexagon socket head set screw (adjustment bolt) so that the screw does not contact with the piston assembly.

Mount the shaft. Key groove or flat direction is the same as the cover direction, and mount the shaft so that the shaft is on the right turning upward by 5 to 10° to horizontal line. If the key groove rotation range is inadequate or displaced, correct the piston assembly to the right position and assemble.

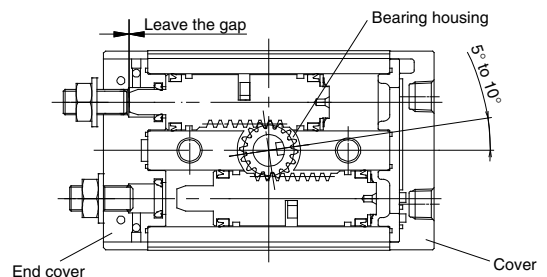

Fig. 10

CRQ2/CRQ2X Series Replacement Procedure for Seals 5

2-4. Mount the bearing retainer, and then tighten the cross recessed no.0 screw or cross recessed round head screw.

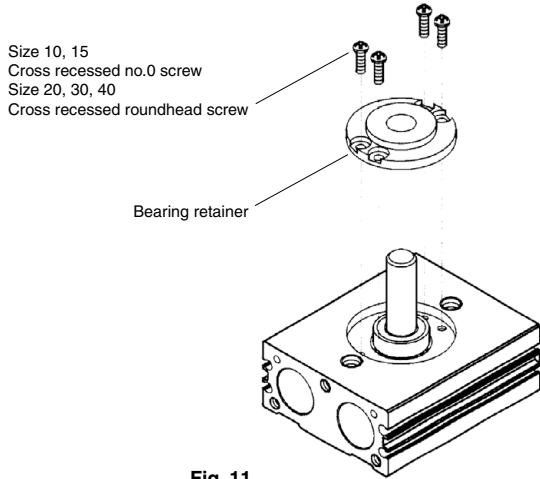

Fig. 11

2-5. Mount the cover assembly and the end cover assembly, and then tighten the hexagon socket head bolt.

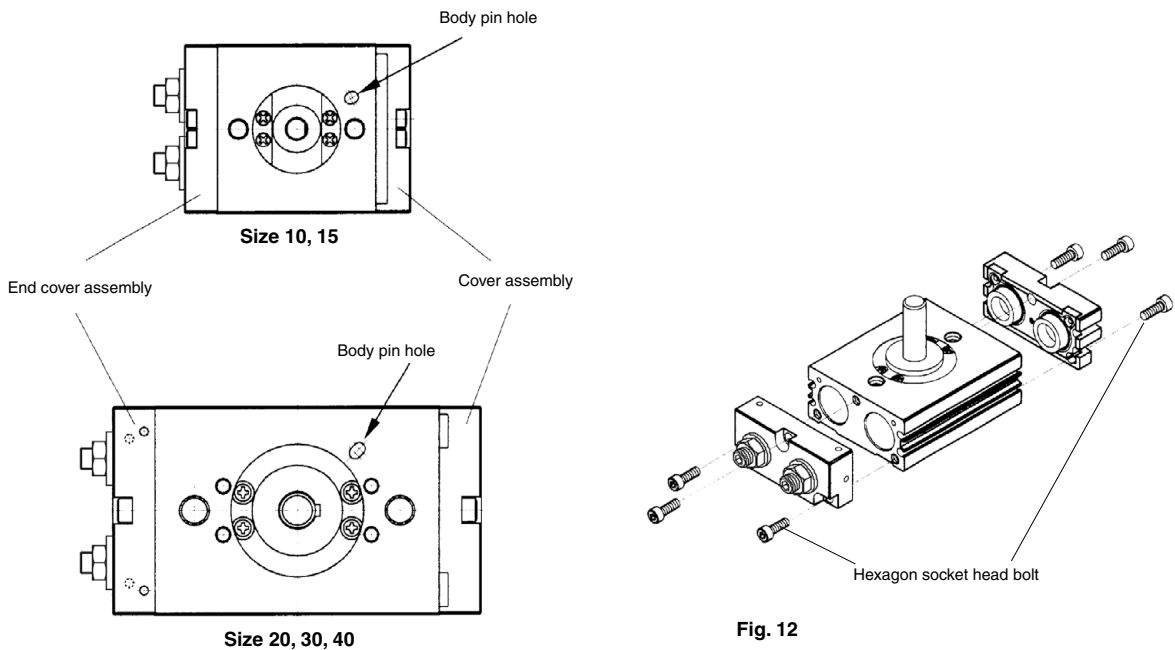
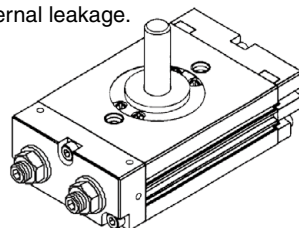

Fig. 12

2-6. Perform an operation test after assembly, and then check for external leakage.



Actuators
Rotary Actuators
Air Grippers
Modular F.R.L.
Pressure Control Equipment
Air Preparation
Equipment
Industrial Filters
Replacement
Procedure
Actuators
Rotary Actuators
Air Grippers
Modular F.R.L.
Pressure Control Equipment
Air Preparation
Equipment
Industrial Filters

MSQ Series Replacement Procedure for Seals 1

Disassembly is not possible for the MSQA10 to 50 as adhesive is used to secure the cover and end cover (MSQ1 to 7), and the high-precision bearing is press-fit to the table (MSQA10 to 50).

1. Disassembly

- 1-1. Loosen the hexagon socket head cap screw and pull out the table. Loosen the hexagon thin socket head bolt (Size 10: Cross recessed round head screw; Size 70, 100, 200: Hexagon socket head cap screw) to remove the bearing retainer.
- 1-2. Pull out the pinion and the bearing from the body.
- 1-3. Loosen the hexagon socket head bolt to remove the cover assembly and the end cover assembly.
- 1-4. Push the piston assembly from one side to pull out the 2 piston assemblies from the body.
(Do not scratch the piston seals when pulling out the piston.)
- 1-5. Take out the bearing from the body. However, for sizes 70, 100, and 200, the bearing on the lower side of the body cannot be removed as the bearing is press-fitted.

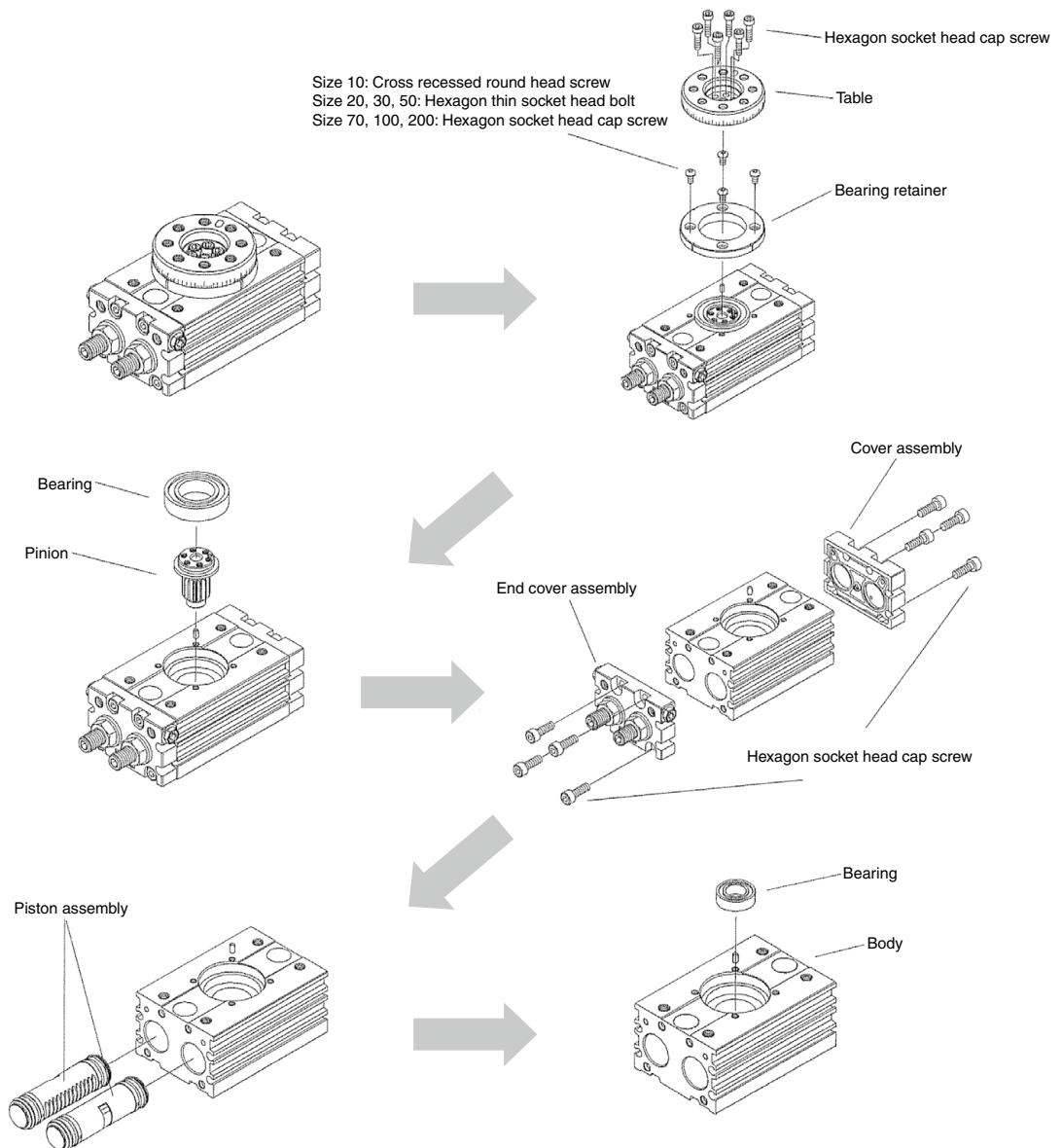

Fig. 1

2. Assembly

2-1. Clean each component sufficiently before assembly to remove any dust etc.

Apply the grease provided in the seal set to each part shown in Table 1. As a guideline, apply enough grease to make the surface shiny.

Table 1 Parts where grease is to be applied

Grease applied parts	Grease
Cylinder internal surface	GR-S-010
Piston seal groove	
Piston seal	
Cover seal	
End cover gasket	
Seal	
O-ring (Size 70, 100, 200)	

Body assembly

Apply grease after wiping the inside of the cylinder with alcohol, and then mount the bearing on the housing.

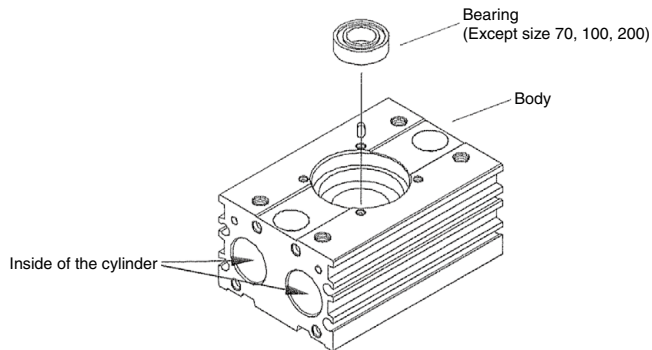

Fig. 2

Piston assembly

Pay attention to the installation direction of the piston seal as the direction is specified. Then mount the piston seal to the piston, taking care not to damage the piston seal.

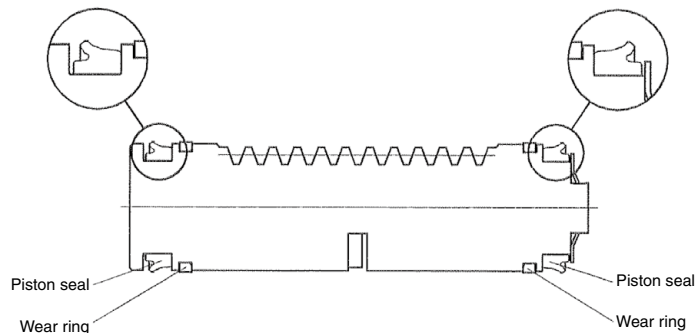

Fig. 3

MSQ Series Replacement Procedure for Seals 3

Cover assembly

Size 10, 20, 30, 50

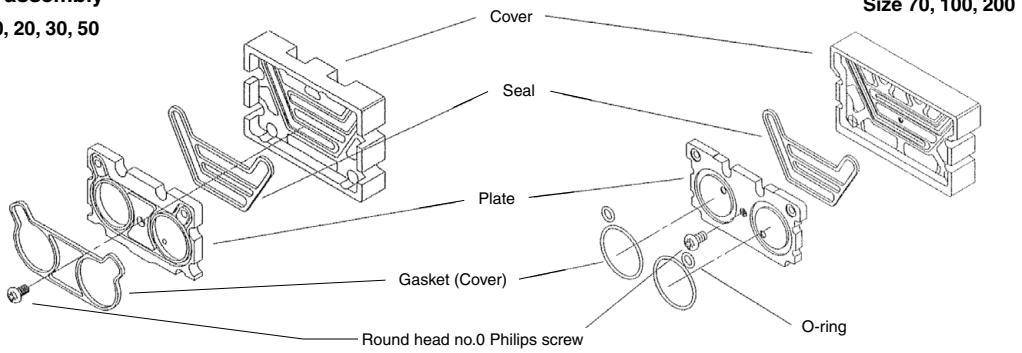
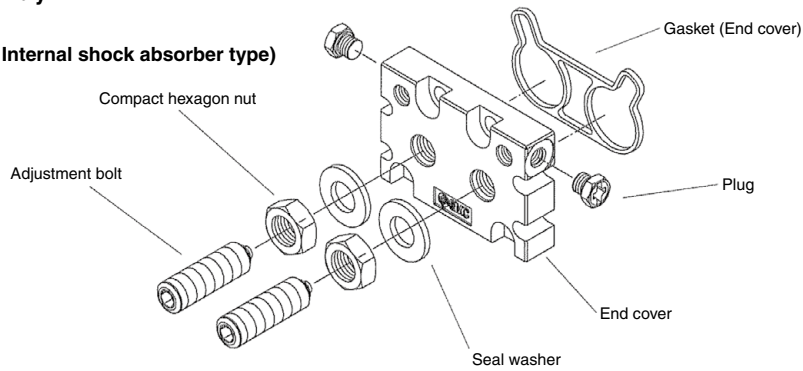

Fig. 4

End cover assembly

Size 10, 20, 30, 50

(Adjustment bolt, Internal shock absorber type)



Size 70, 100, 200

(Adjustment bolt, Internal shock absorber type)

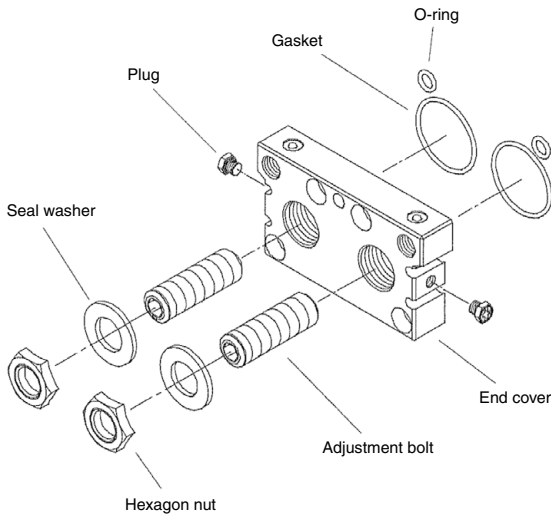

Size 10, 20, 30, 50

(External shock absorber type)

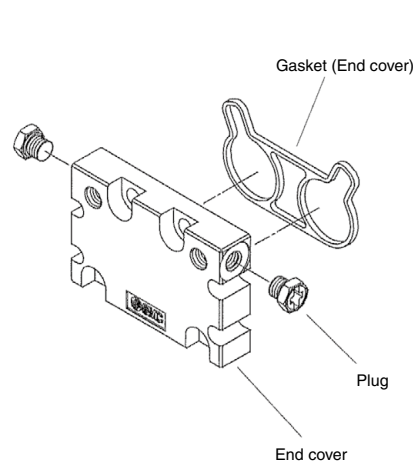
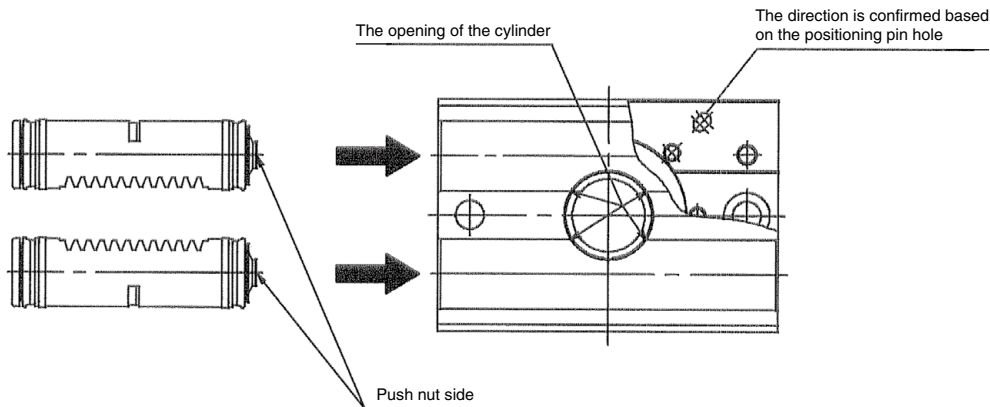

Fig. 5

MSQ Series Replacement Procedure for Seals 4

2-2. Insert the piston assembly into the body assembly. In this case, the piston seals pass through the cylinder opening, so install the seals into the opening while squeezing them to prevent the seals from being damaged. Pay attention to the insertion direction of the piston and the body as they are specified. (Fig. 6)

Fig. 6



2-3. Hold the piston in place and install the pinion gear on the piston.

Fig. 7 shows the piston position and Fig. 8 shows the pinion gear assembly angle.

Fig. 7

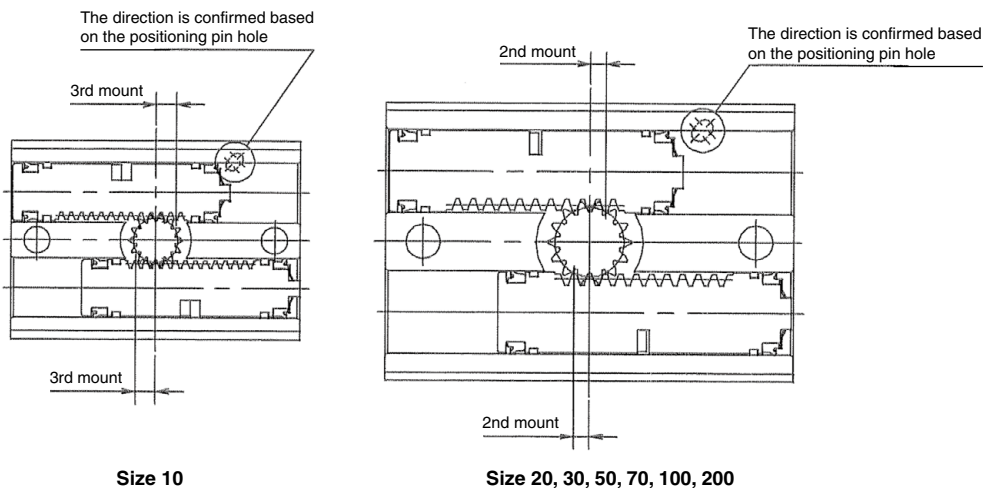
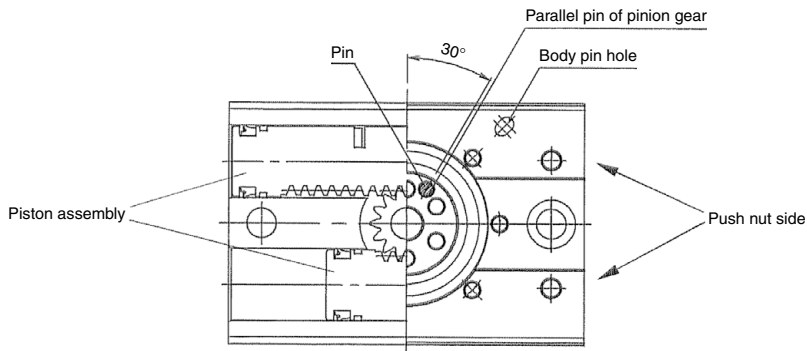

Fig. 8



Actuators
 Rotary Actuators
 Air Grippers
 Modular F.R.L.
 Pressure Control Equipment
 Air Preparation
 Equipment
 Industrial Filters
 Replacement
 Procedure
 Actuators
 Rotary Actuators
 Air Grippers
 Modular F.R.L.
 Pressure Control Equipment
 Air Preparation Equipment
 Industrial Filters

JMHZ2 Series Replacement Procedure for Seals 1

1. Exploded View

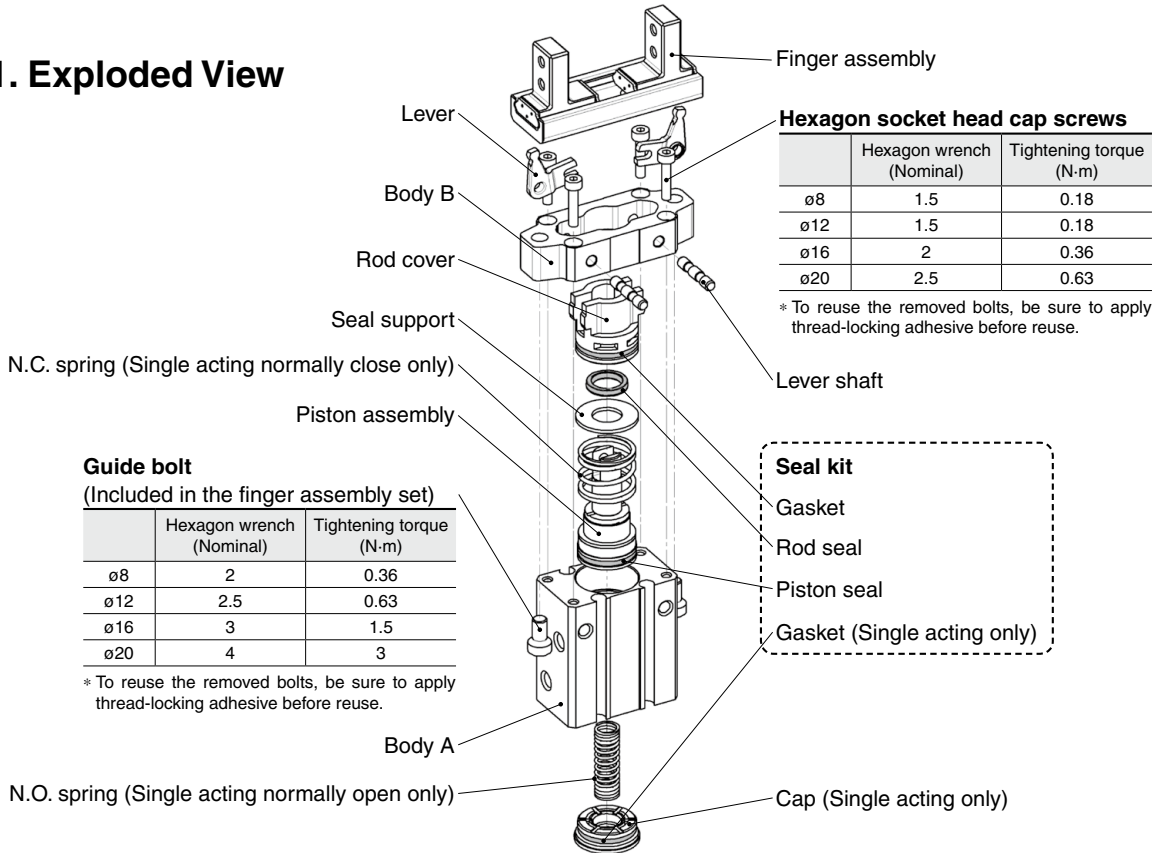

2. Replacement of the Seal

2-1. Loosen the guide bolts, and then remove the finger assembly.

2-2. Loosen the hexagon socket head cap screws, and then remove them from Body A.

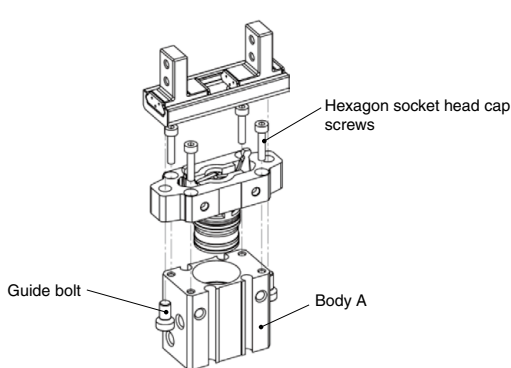

2-3. Push the seal support so that the rod cover comes out of Body B end surface.

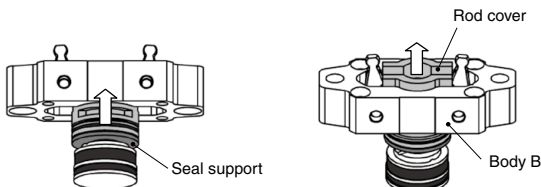

2-4. Remove the lever shaft and lever.

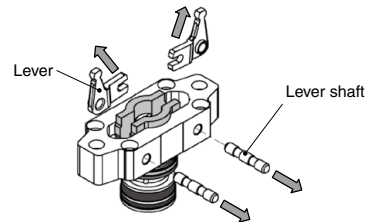

2-5. Pull out the rod cover and piston assembly, and then replace the seal.

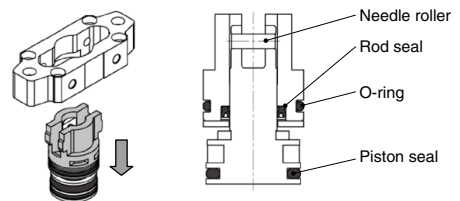

Assembly should be performed by following the removal procedure in reverse.

Refer to the disassembly drawing for the tightening torque for the bolt.

Use a specified grease.

Grease pack part no: GR-S-010 (10 g)

3. Finger Assembly Set Replacement

3-1. Direction of the body of the drawing on the right is recommended for mounting the finger assembly to the body.

⚠ Caution

For $\phi 8$, use a hexagon wrench with a ball end. Mount the finger assembly and Body A with care so that the guide bolts do not interfere with Body A.

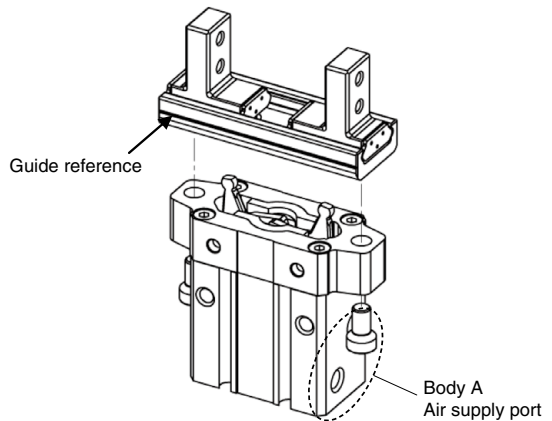

3-2. The guide may be displaced during tightening of the guide bolts. In order to avoid this displacement, place the guide and Body A on a flat surface and insert a spacer to fill the gap between the surface and guide (with reference line face down).

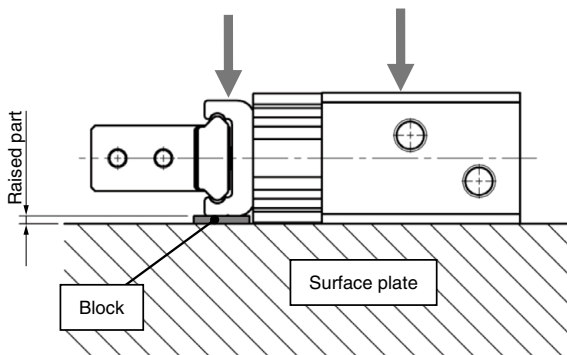

With across flat of the guide bolt and tightening torque

	Width across flats (Nominal)	Tightening torque (N·m)	Spacer size required (mm)
$\phi 8$	2	0.36	1.7
$\phi 12$	2.5	0.63	1.2
$\phi 16$	3	1.5	1.2
$\phi 25$	4	3	2.4

* To reuse the removed bolts, be sure to apply thread-locking adhesive before reuse.

Actuators

Rotary Actuators
Air Grippers

Modular F.R.L.
Pressure Control Equipment

Air Preparation
Equipment

Industrial Filters

Replacement
Procedure

Actuators

Rotary Actuators
Air Grippers

Modular F.R.L.
Pressure Control Equipment

Air Preparation Equipment
Industrial Filters

MHZ2/MHZL2/MHZJ2 Series Replacement Procedure for Seals 1

1. Exploded View

MHZ2 Series

ø10 to ø25

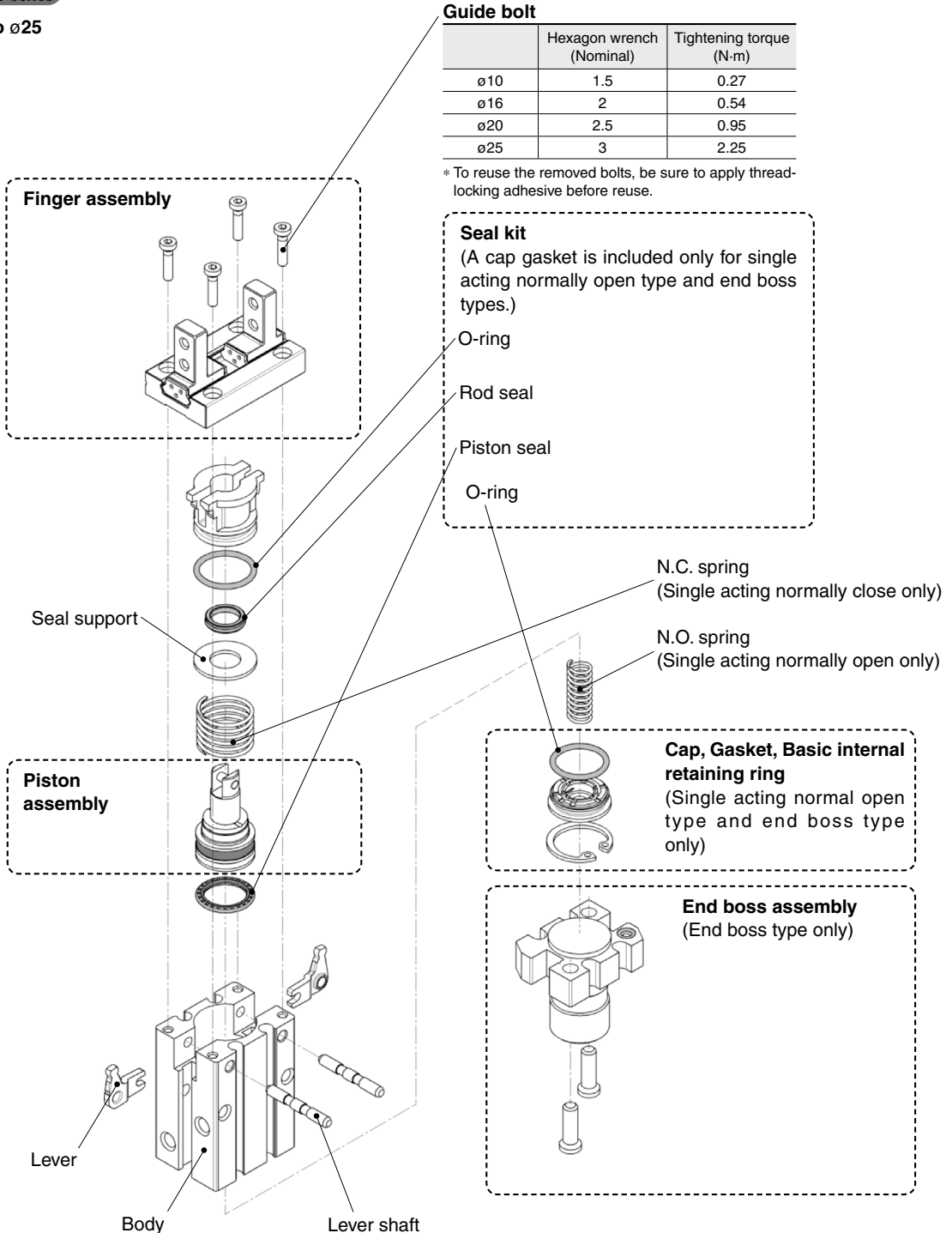

MHZ2/MHZL2/MHZJ2 Series Replacement Procedure for Seals 2

MHZ2 Series

ø32, ø40

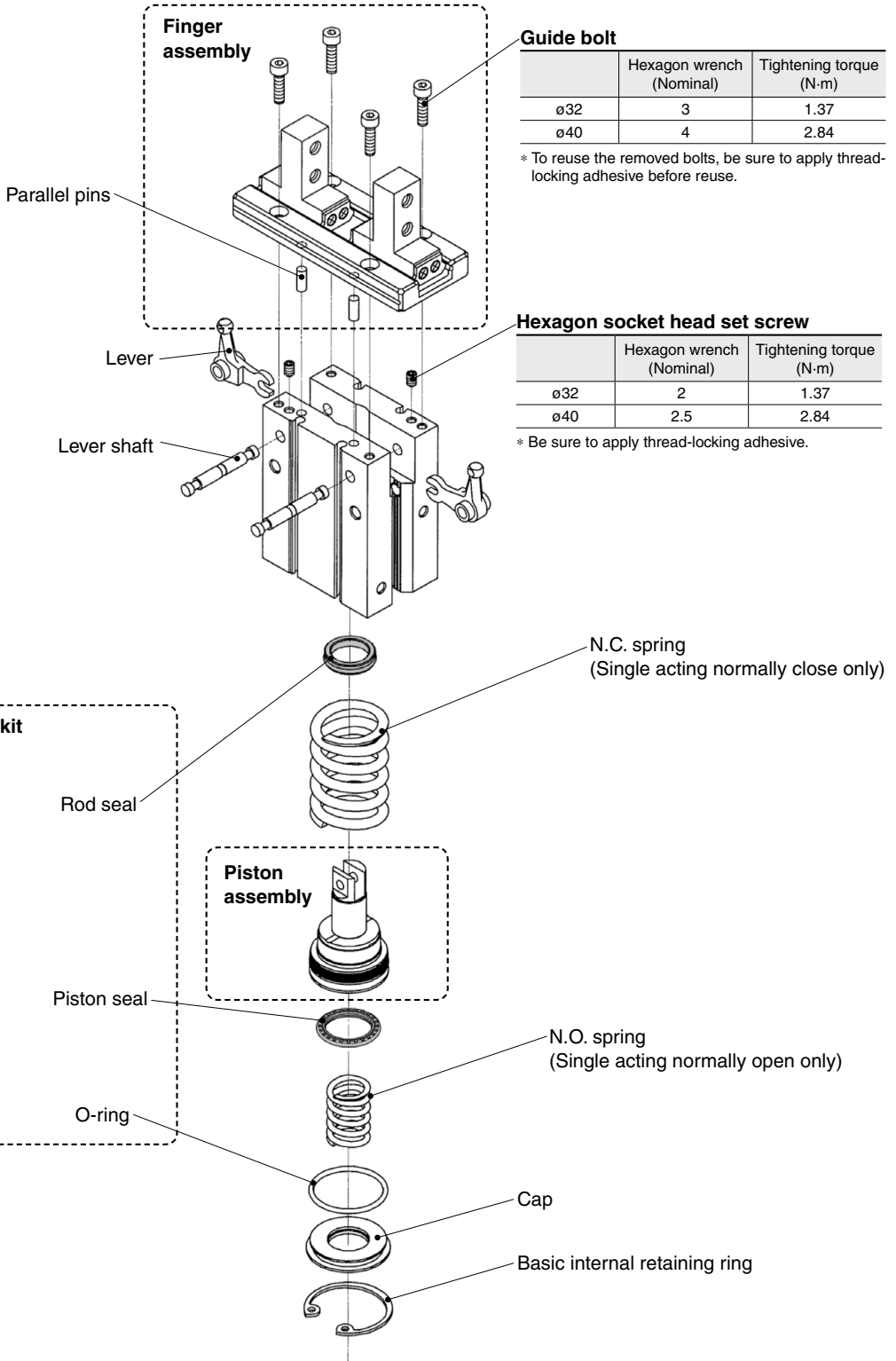

MHZ2/MHZL2/MHZJ2 Series Replacement Procedure for Seals 3

MHZL2/MHZJ2 Series

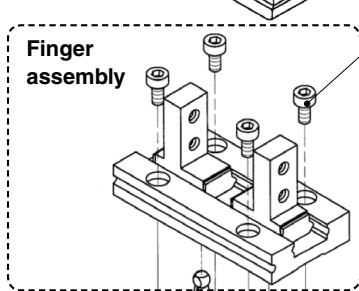
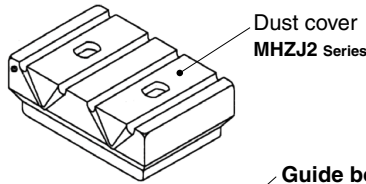

Guide bolt
MHZL2/MHZJ2 Series

	Hexagon wrench (Nominal)	Tightening torque (N·m)
ø10	1.5	0.27
ø16	2	0.54
ø20	2.5	0.95
ø25	3	2.25

* To reuse the removed screws, be sure to apply thread-locking adhesive before reuse.

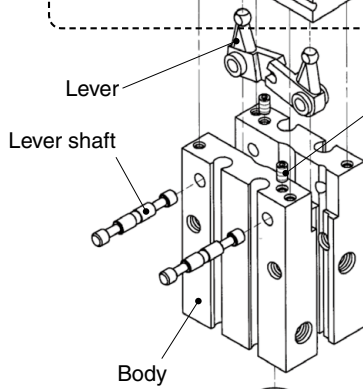

Hexagon socket head set screw
MHZL2/MHZJ2 Series

	Hexagon wrench (Nominal)	Tightening torque (N·m)
ø10	0.9	0.15
ø16	1.3	0.31
ø20	1.5	0.59
ø25	2	1.37

* Be sure to apply thread-locking adhesive.

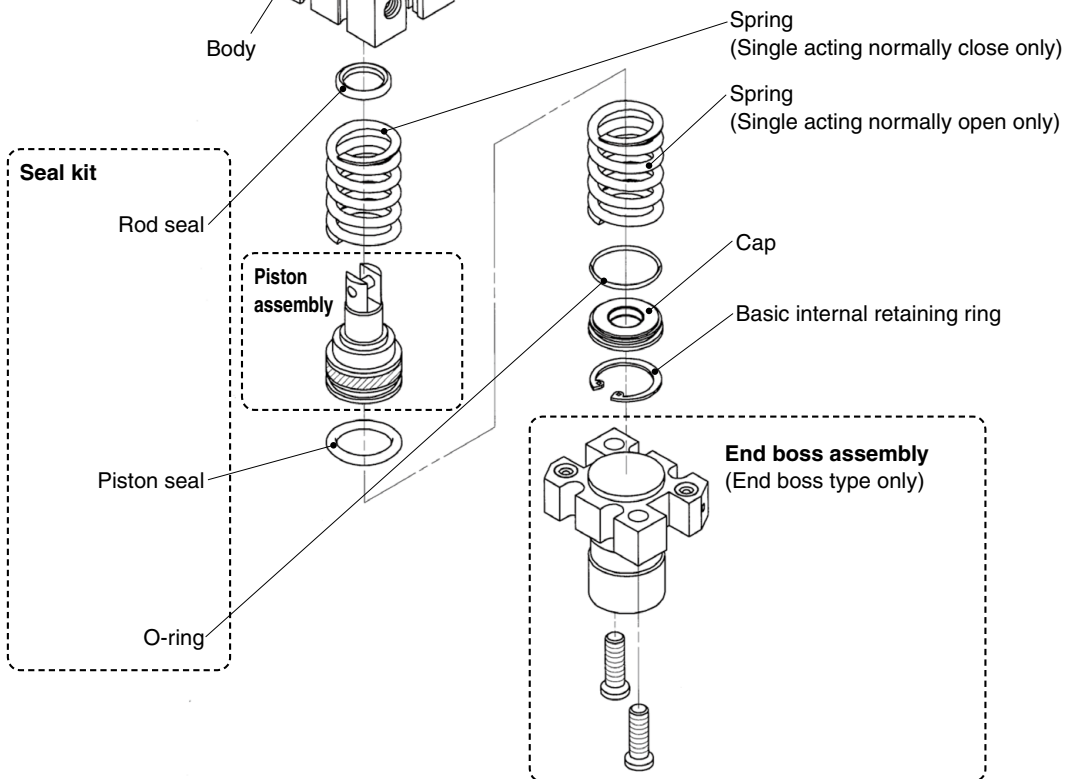

2. Replacement of the Seal

2-1. Remove the basic internal retaining ring with the specified tool, and then remove the cap.

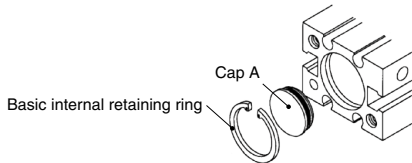

2-2. Loosen the guide bolts, and then remove the guide.

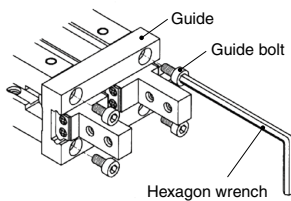

Hexagon wrench size	
	Nominal
ø32	3
ø40	4

MHZL2/MHZJ2 Series Hexagon wrench size	
	Nominal
ø10	1.5
ø16	2
ø20	2.5
ø25	3

2-3. Loosen the guide bolts, and then pull out the lever shaft to move the lever.

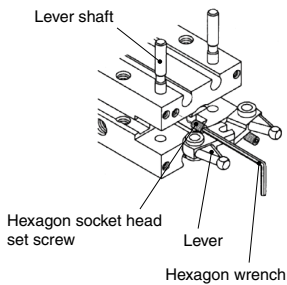

Hexagon wrench size	
	Nominal
ø32	2
ø40	2.5

MHZL2/MHZJ2 Series Hexagon wrench size	
	Nominal
ø10	0.9
ø16	1.3
ø20	1.5
ø25	2

2-4. Remove the piston assembly, and then replace the seal.

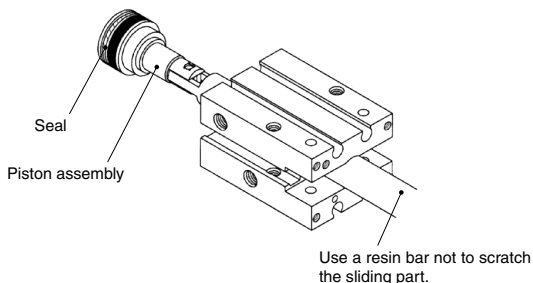

Assembly should be performed by following the removal procedure in reverse.
 Refer to the disassembly drawing for the tightening torque for the guide bolt and hexagon socket head set screws.
 Use a specified grease.
Grease pack part no: GR-S-010 (10 g)

MHZ2 Series

ø10 to ø25

- Loosen the guide bolts, and then remove the finger assembly.
- Open the lever and have the rod cover come out of the body end surface.



- Push the protrusions of the rod cover to have the rod cover pop out.

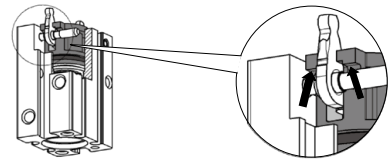

- Remove the lever shaft and lever.

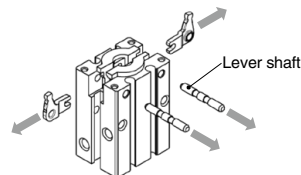

- Pull out the piston assembly, and then replace the seal.

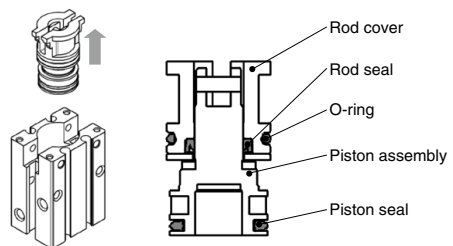

Assembly should be performed by following the removal procedure in reverse.
 Refer to the disassembly drawing for the tightening torque for the guide bolt.
 Use a specified grease.

Grease pack part no: GR-S-010 (10 g)
 When the O-ring for single acting normal open type or end boss type cap is replaced, it is necessary to remove the basic internal retaining ring.

3. Finger Assembly Set Replacement

MHZ2/MHZL2/MHZJ2

3-1. Direction of the body of the drawing below is recommended for mounting the finger assembly to the body.

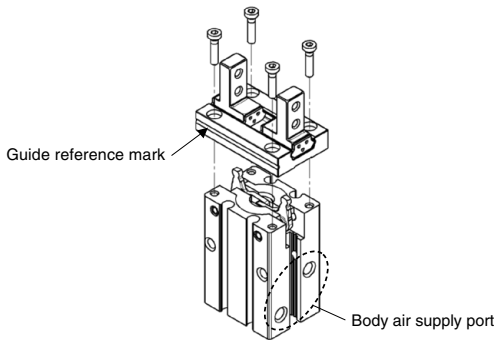

Note 1) The old model has the 2 positioning pins at the joint of the body and guide. These pins are not necessary. Please remove them.

Note 2) As the old MHZL2-16 model has a shallow screw depth, the current finger assembly cannot be mounted on the product. For mounting, please request servicing from the SMC factory.

3-2. The guide may be displaced during tightening of the guide bolts. In order to avoid the displacement, insert the 0.2 mm of gap gauge near the guide reference mark and press the guide and body to the surface plate.

With across flat of the guide bolt and tightening torque

	Width across flats (Nominal)	Tightening torque (N·m)
ø10	1.5	0.27
ø16	2	0.54
ø20	2.5	0.95
ø25	3	2.25

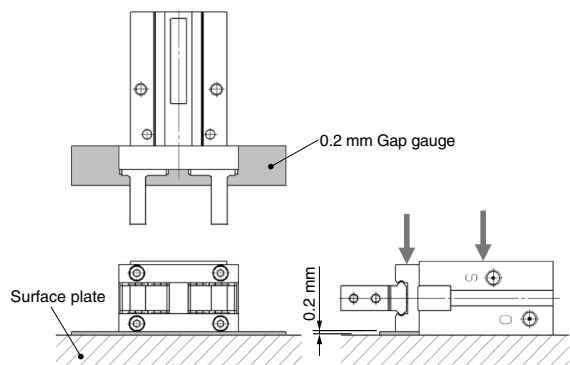

MHZJ2 Series

Replacement of the Dust Cover

<Removal of the Dust Cover>

1. Hold the shaded regions indicated in the picture (▨) of the cover. Remove the dust cover from the body groove carefully.
2. When the bead of the dust cover is separated from the body groove, pull the shaded part in direction of the finger.
3. When all the bead of the dust cover is out of the body groove, pull the cover in direction shown by arrow to remove it from the air gripper.

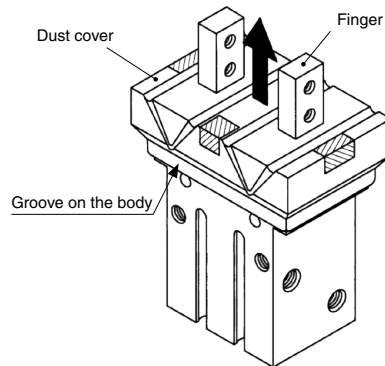

<Mounting of the Dust Cover>

1. Put the dust cover on the finger.
2. Attach the dust cover to the groove of the finger.
3. Push the bead of the dust cover into the hole in the body groove.

Note) Be careful not to tear the dust cover during mounting or removal of the dust cover. Also, be careful not to twist the finger.

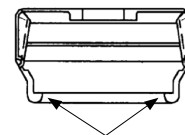

The bead of the dust cover

Cross section for the dust cover

MHF2 Series Replacement Procedure for Seals 1

1. Exploded View

Applicable model: MHF2-8D, MHF2-8D1

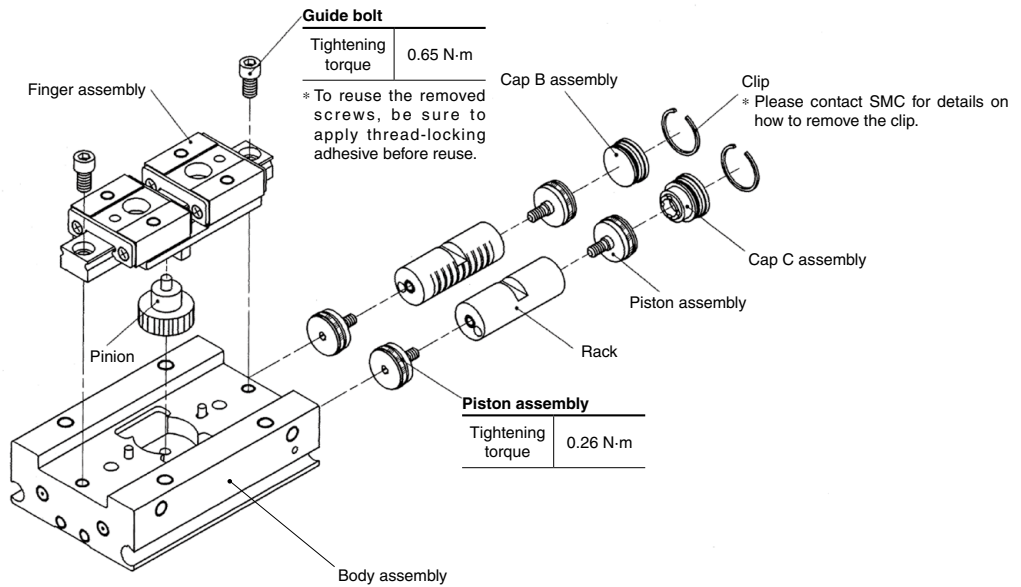

Applicable model: MHF2-8D2, MHF2-12D□ to 20D□

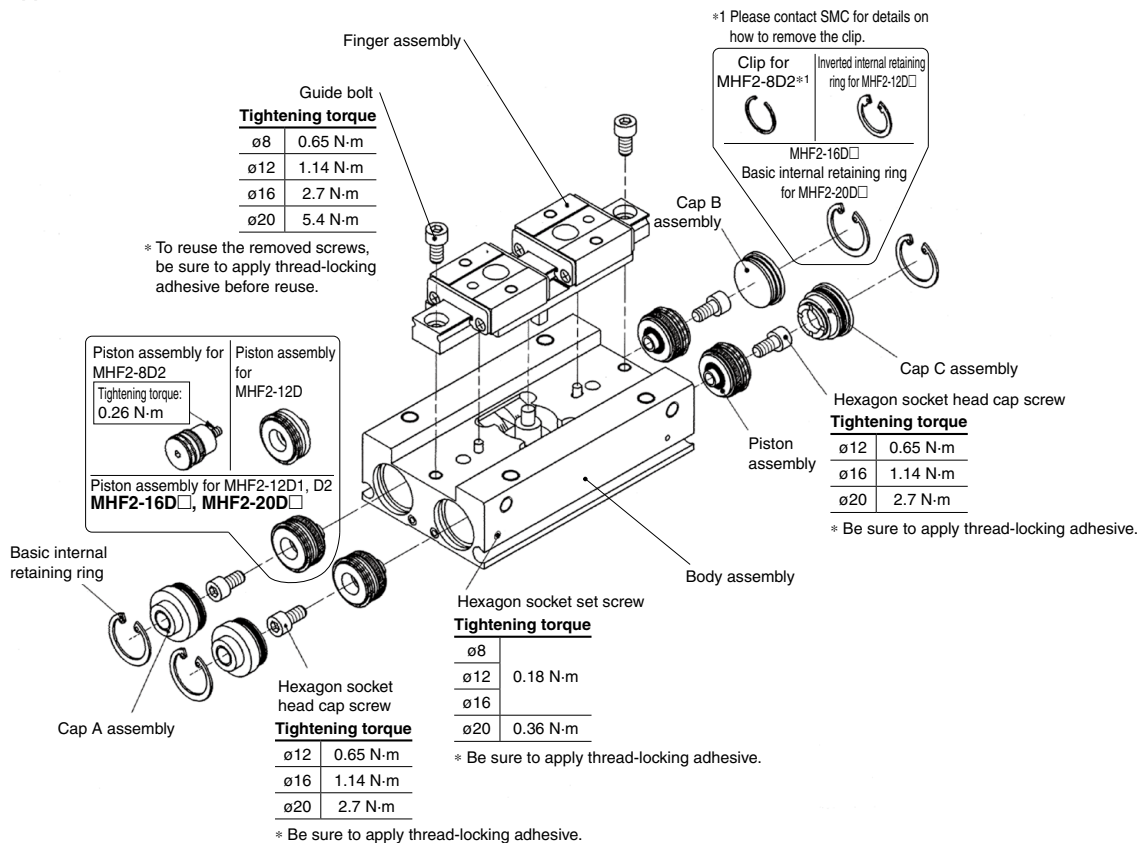

Actuators

Rotary Actuators
Air Grippers

Modular F.R.L.
Pressure Control Equipment

Air Preparation
Equipment

Industrial Filters

Replacement
Procedure

Actuators

Rotary Actuators
Air Grippers

Modular F.R.L.
Pressure Control Equipment

Air Preparation Equipment
Industrial Filters

MHF2 Series Replacement Procedure for Seals 2

2. Replacement of the Seal

Applicable model: MHF2-8D, MHF2-8D1

2-1. Loosen the guide bolts, and then remove the finger assembly.

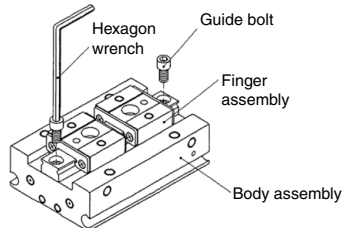

Hexagon wrench size	
	Nominal
ø8	2

2-2. Remove the clips, cap B assemblies, and cap C assemblies.

* Please contact SMC for details on how to remove the clip.

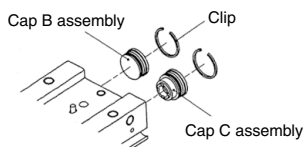

2-3. Remove the pinion. (Make sure to align the groove of the rack and the pinion shaft when they are assembled.)

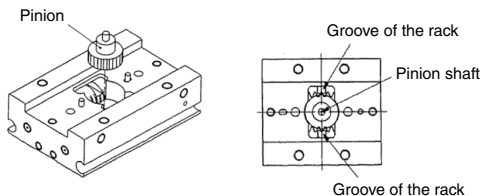

2-4. Remove the rack assembly, and then replace the seal.

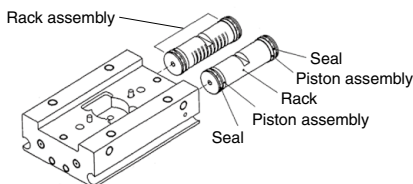

Assembly should be performed by following the removal procedure in reverse.

Refer to the disassembly drawing for the tightening torque for the guide bolt.

Use a specified grease.

Grease pack part no For guide: GR-S-010 (10 g), For cylinder: GR-L-005 (5 g)

Applicable model: MHF2-8D2, MHF2-12D□ to 20D□

2-1. Loosen the guide bolts, and then remove the finger assembly.

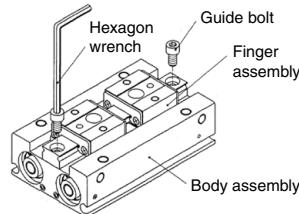

Hexagon wrench size	
	Nominal
ø8	2
ø12	2.5
ø16	3
ø20	4

2-2. Loosen the hexagon socket set screws to remove the ø8 clips, ø12 inverted internal retaining rings, ø16 and ø20 basic internal retaining ring, caps A, caps B and caps C.

* Please contact SMC for details on how to remove the clip.

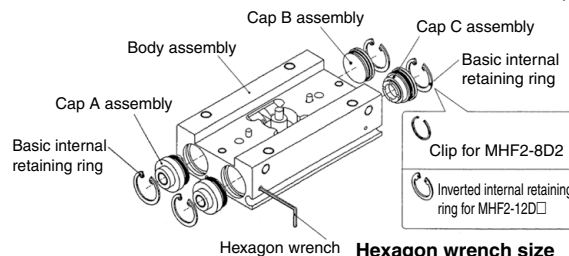

Hexagon wrench size	
	Nominal
ø8	
ø12	0.9
ø16	
ø20	1.3

2-3. Loosen the hexagon socket head cap screws on the ø8 piston assemblies to remove the piston assembly, and then replace the seal. (Mounting direction of seals more than ø12 is specified.)

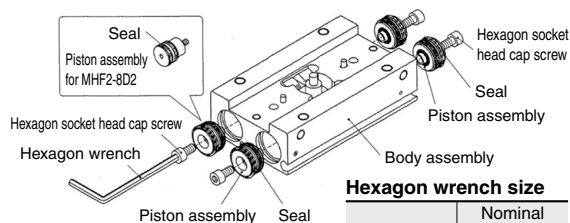

Hexagon wrench size	
	Nominal
ø8	1.5
ø12	2
ø16	2.5
ø20	3



⚠ Caution

Mounting direction of the seals more than ø12.

Assembly should be performed by following the removal procedure in reverse. Refer to the disassembly drawing for the tightening torque for the guide bolts, hexagon socket set screws, and hexagon socket head set screws.

Use a specified grease.

Grease pack part no For guide: GR-S-010 (10 g), For cylinder: GR-L-005 (5 g) or GR-L-010 (10 g)

MHL2(-Z) Series Replacement Procedure for Seals

1. Replacement of the Piston Assembly

1-1. Loosen the U nut, and then remove the conical spring washer, finger, and washer.

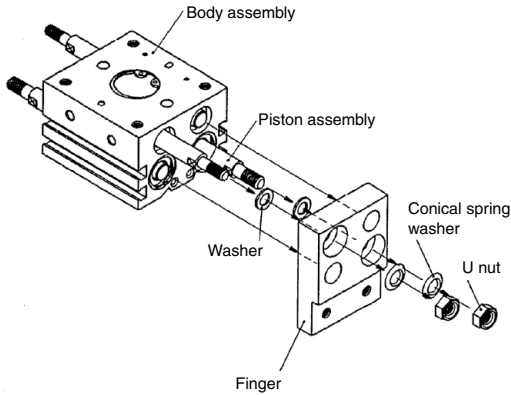

1-2. Remove the inverted internal retaining ring with a retaining ring tool.

1-3. Remove rod seal cover B and the rod cover assembly.

1-4. Pull out the piston assembly.

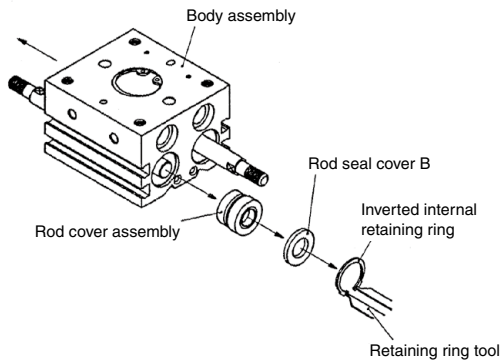

2. Replacement of the Seal Set

2-1. Replacement of the piston seal

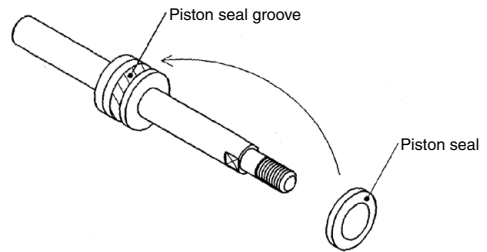

2-2. Replacement of the rod seal for the body rack

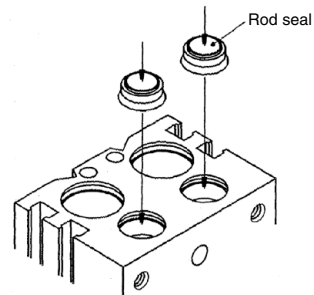

2-3. Replacement of the O-ring and the rod seal for the rod cover assembly

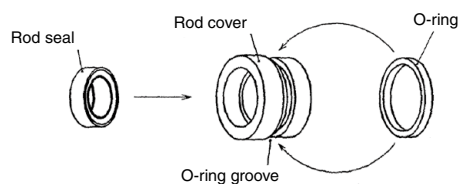

MHR3/MDHR3 Series Replacement Procedure for Cover

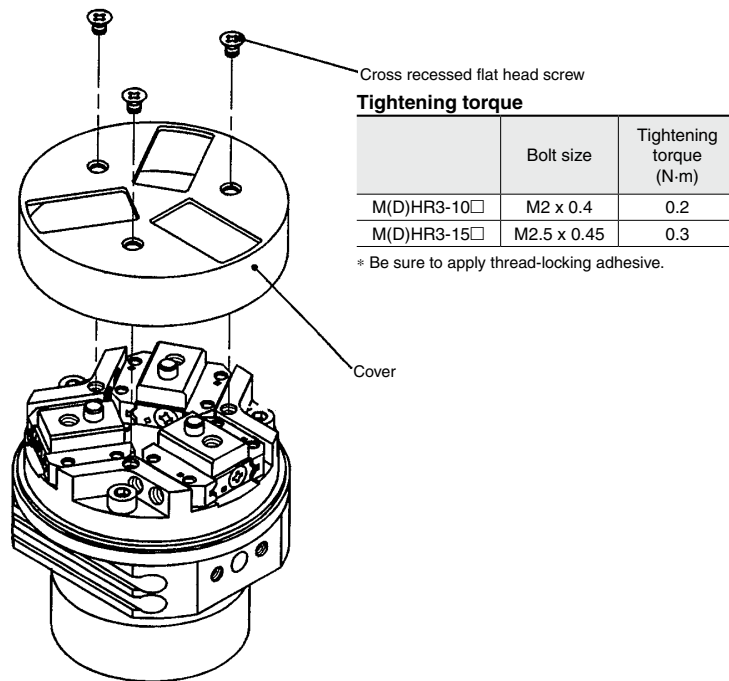

MHK2 Series Replacement Procedure for Seals

1. Replacement of the Piston Assembly

1-1. Remove the basic internal retaining ring, the cap, and the O-ring.

1-2. Loosen the piston bolt with a hexagon wrench.

Hexagon wrench size

	Width across flats (mm)
ø12	2.5
ø16	2.5
ø20	2.5
ø25	4

1-3. Take out the piston assembly, and then replace the seal.

1-4. Follow this procedure backward for assembly.

	Applicable bolt size	Width across flats	Tightening torque (N·m)
ø12	M3 x 0.5	2.5	0.9
ø16	M3 x 0.5	2.5	0.9
ø20	M3 x 0.5	2.5	0.9
ø25	M5 x 0.8	4	4.2

* Be sure to apply thread-locking adhesive.

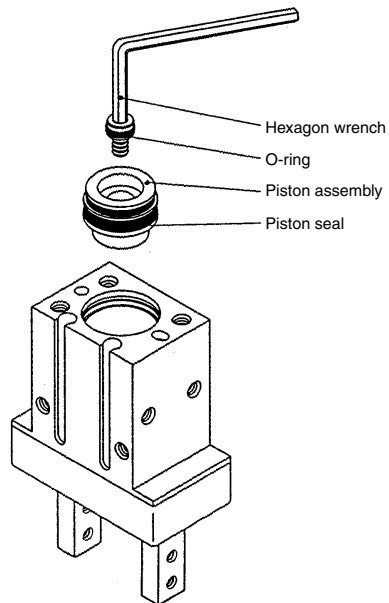
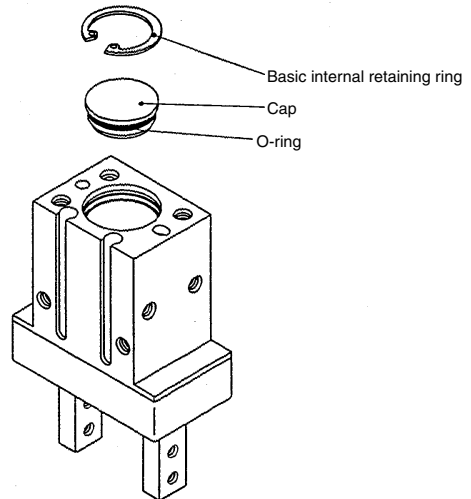

Actuators

Rotary Actuators
Air Grippers

Modular F.R.L.
Pressure Control Equipment

Air Preparation
Equipment

Industrial Filters

Replacement
Procedure

Actuators

Rotary Actuators
Air Grippers

Modular F.R.L.
Pressure Control Equipment

Air Preparation Equipment
Industrial Filters

1. Exploded View

MHS2
MHS3
MHS4

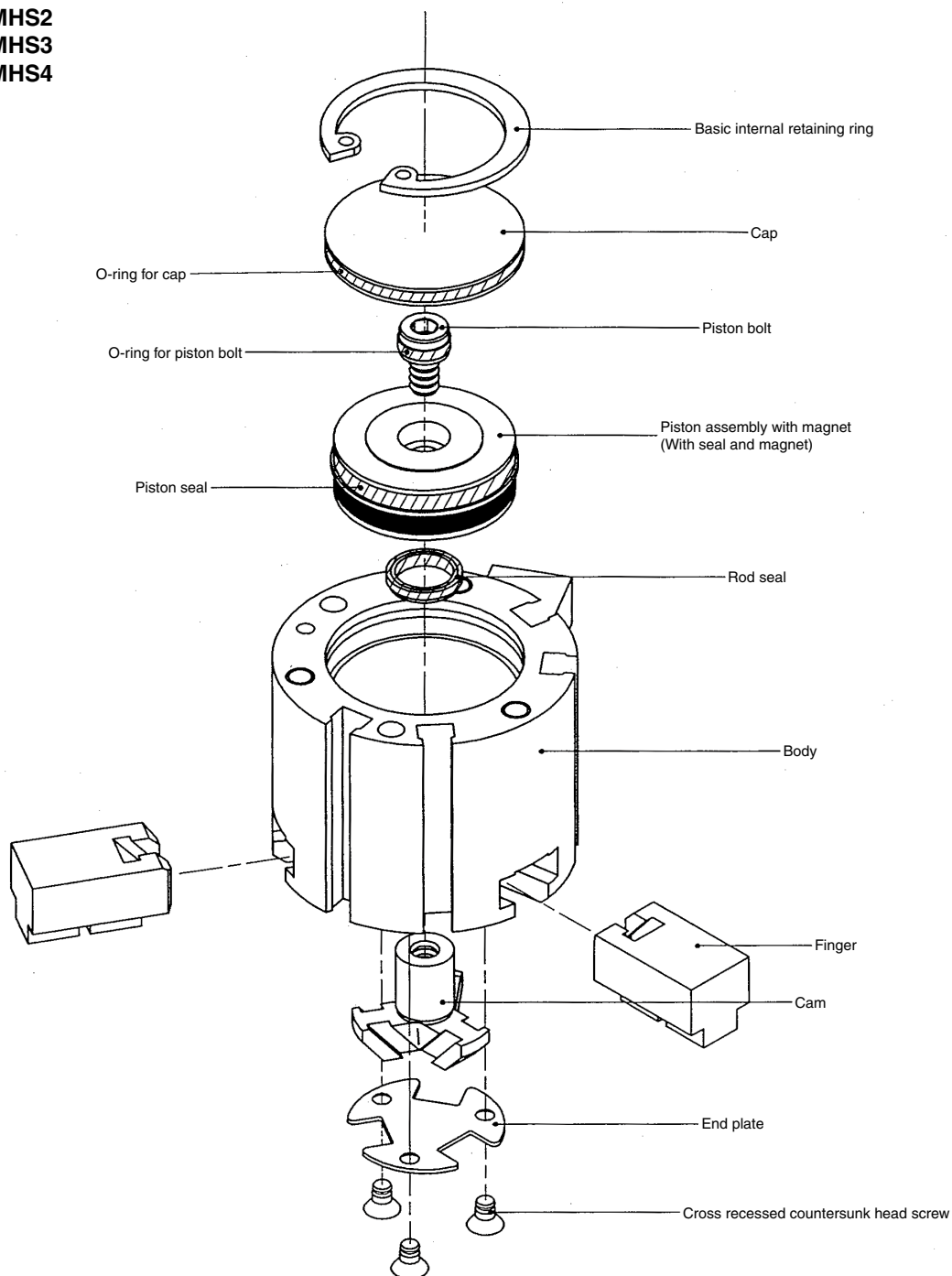

There are no major differences in construction between the MHS3 and the MHS2 and MHS4.
Disassemble while referring to the disassembly instructions for the MHS3.

2. Replacement of the Seal

MHS3

2-1. Remove the basic internal retaining ring with the specified tool, and then remove the cap.

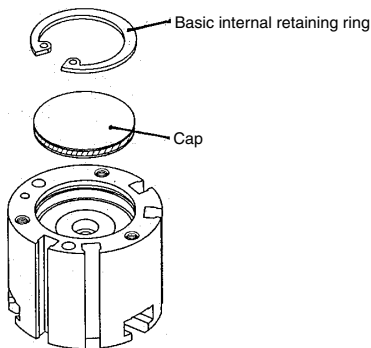

2-2. Remove the piston bolt.

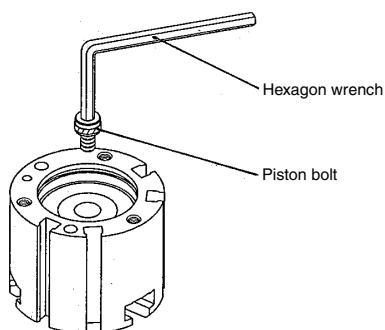

	Applicable bolt size	Hexagon width across flats	Tightening torque (N·m)
ø16	M3 x 0.5	2.5	0.6
ø20	M3 x 0.5	2.5	0.6
ø25	M4 x 0.7	3	1.4
ø32	M5 x 0.8	4	5.1
ø40	M5 x 0.8	4	5.1
ø50	M6 x 1	5	8.6
ø63	M8 x 1.25	6	21.6
ø80	M10 x 1.5	8	24
ø100	M12 x 1.75	10	42.2
ø125	M14 x 2	12	67.7

* Be sure to apply thread-locking adhesive.

2-3. Remove the piston, and then replace the seal.

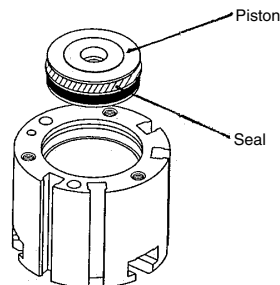

2-4. Unscrew the cross recessed countersunk head screws, and then remove the end plate.

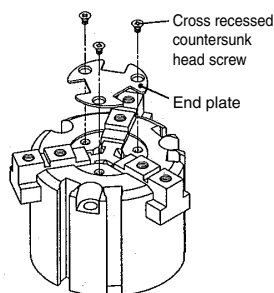

	Bolt size	Tightening torque (N·m)
ø16	M2 x 0.4	0.2
ø20	M2 x 0.4	0.2
ø25	M2 x 0.4	0.2
ø32	M2 x 0.4	0.2
ø40	M3 x 0.5	0.6
ø50	M3 x 0.5	0.6
ø63	M3 x 0.5	0.6
ø80	M4 x 0.7	1.4
ø100	M4 x 0.7	1.4
ø125	M4 x 0.7	1.4

* Be sure to apply thread-locking adhesive.

2-5. Open fingers, and then remove the cam.

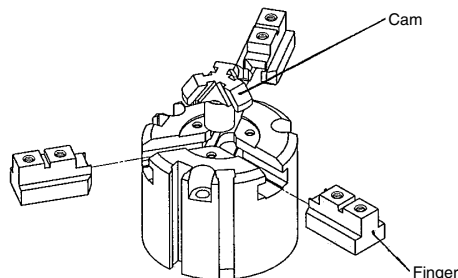

Assembly should be performed by following the removal procedure in reverse.

Use a specified grease.

Grease pack part no: MH-G01 (30 g)

Actuators
 Rotary Actuators
 Air Grippers
 Modular F.R.L.
 Pressure Control Equipment
 Air Preparation Equipment
 Industrial Filters
 Replacement Procedure
 Actuators
 Rotary Actuators
 Air Grippers
 Modular F.R.L.
 Pressure Control Equipment
 Air Preparation Equipment
 Industrial Filters

MHSJ3 Series Replacement Procedure for Seals 1

1. Exploded View

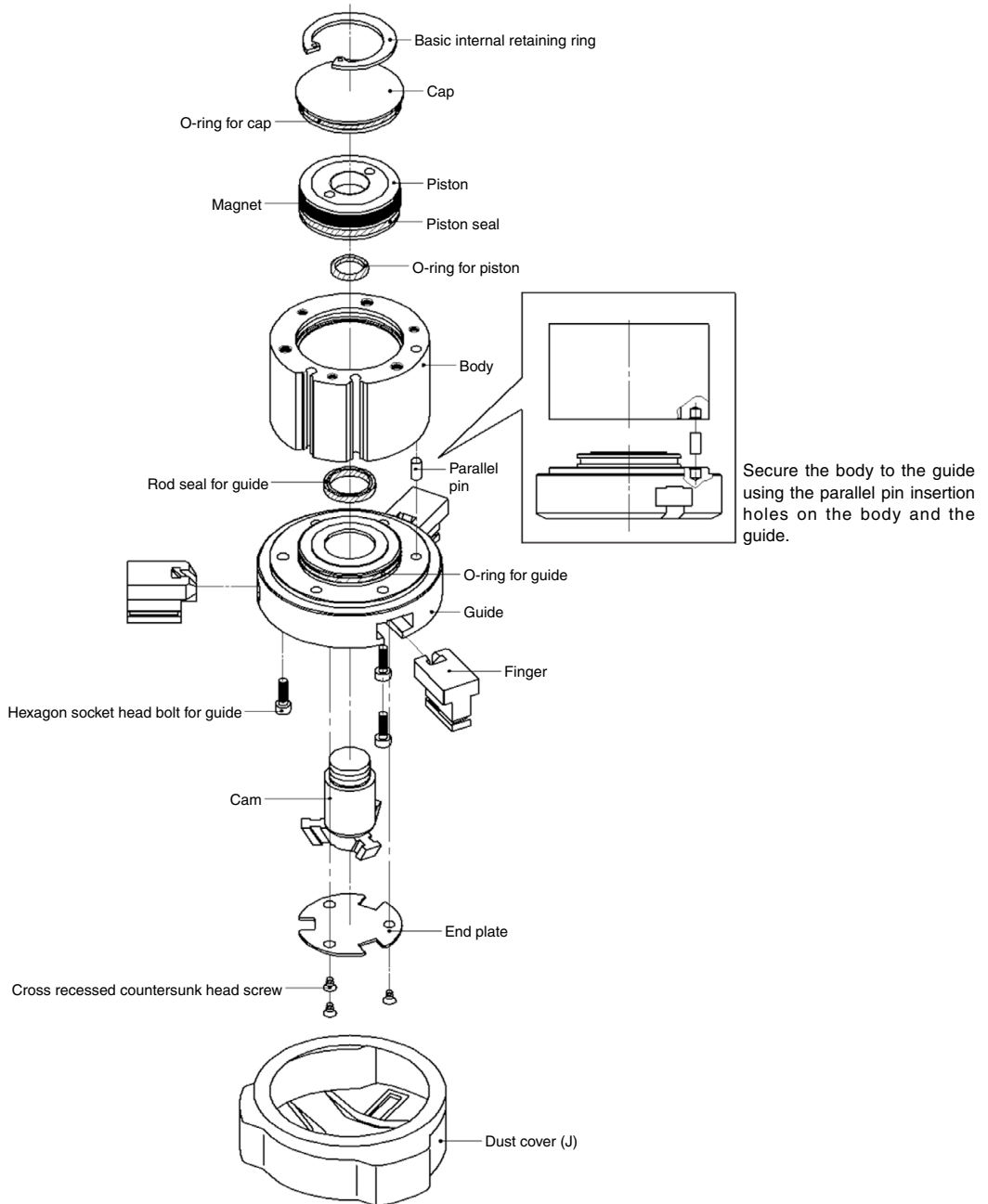

MHSJ3 Series Replacement Procedure for Seals 2

2. Replacement of the Seal

2-1. Remove dust cover (J).

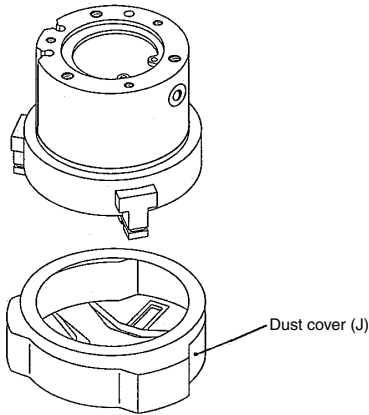

2-2. Remove the basic internal retaining ring with the specified tool, and then remove the cap.

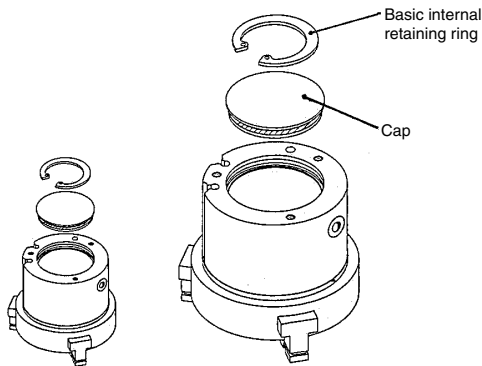

2-3. Using the specialized tool, remove the piston, and then replace the seal.

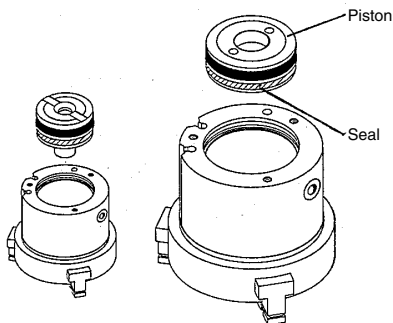

To remove the piston from the cam, one of SMC's specialized tools is required. Please contact SMC before disassembling the product.

2-4. Unscrew the cross recessed countersunk head screws, and then remove the end plate.

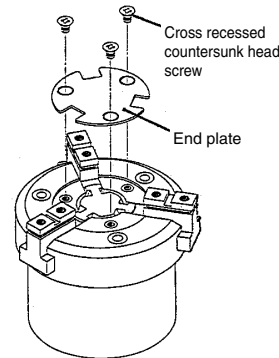

	Bolt size	Tightening torque (N·m)
ø16	M1.7 x 0.35	0.15
ø20	M2 x 0.4	0.2
ø25	M2 x 0.4	0.2
ø32	M2 x 0.4	0.2
ø40	M3 x 0.5	0.6
ø50	M3 x 0.5	0.6
ø63	M3 x 0.5	0.6
ø80	M4 x 0.7	1.4

* Be sure to apply thread-locking adhesive.

2-5. Open fingers, and then remove the cam.

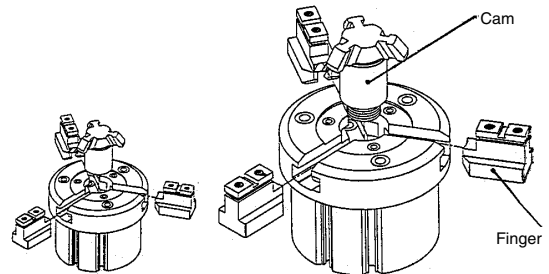

2-6. Loosen the hexagon socket head cap screw, and then remove the guide and body.

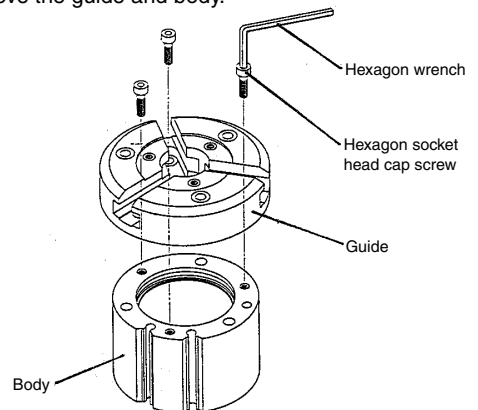

	Applicable bolt size	Hexagon width across flats	Tightening torque (N·m)
ø16	M2.5 x 0.45	2	0.3
ø20	M3 x 0.5	2.5	0.6
ø25	M3 x 0.5	2.5	0.6
ø32	M4 x 0.7	3	1.4
ø40	M4 x 0.7	3	1.4
ø50	M5 x 0.8	4	2.8
ø63	M5 x 0.8	4	2.8
ø80	M6 x 1	5	4.8

* Be sure to apply thread-locking adhesive.

MHSH3/MHSHJ3 Series Replacement Procedure for Seals 1

1. Exploded View

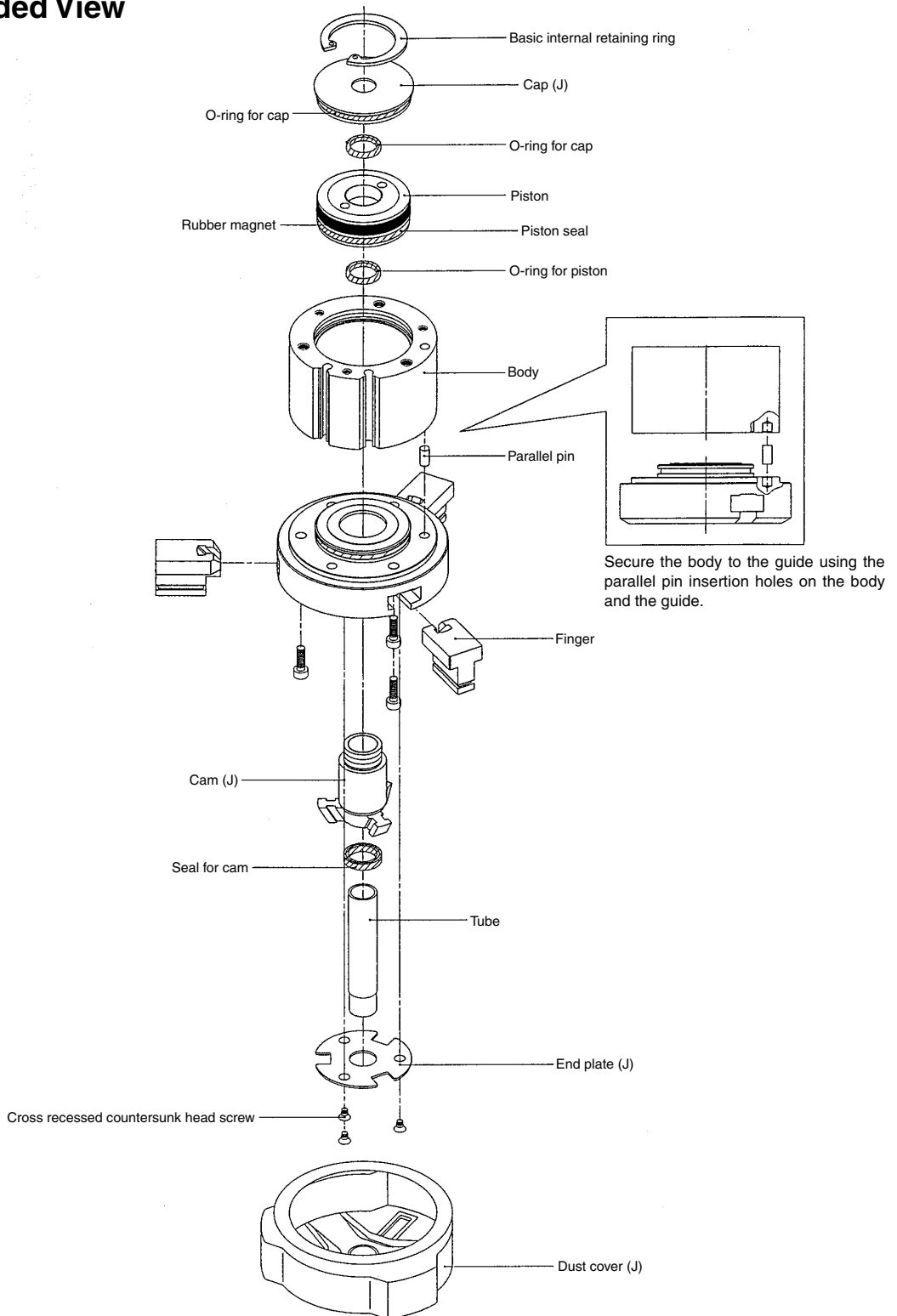

2. Replacement of the Seal

2-1. Remove the basic internal retaining ring with the specified tool, and then remove the cap. At the same time, pull the tube out.

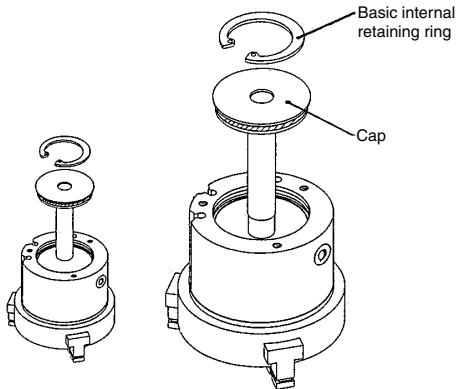

2-2. Using the specialized tool, remove the piston, and then replace the seal.

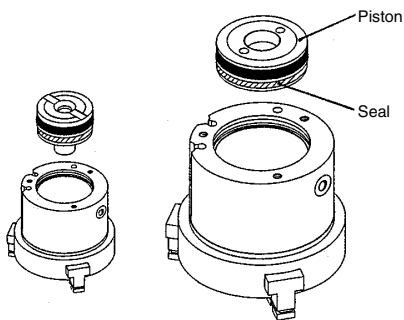

To remove the piston from the cam, one of SMC's specialized tools is required. Please contact SMC before disassembling the product.

2-3. Unscrew the cross recessed countersunk head screws, and then remove the end plate.

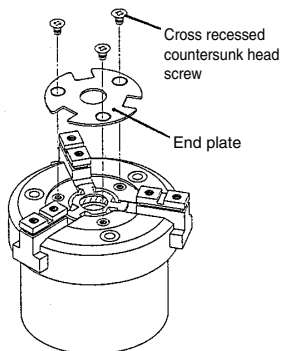

	Bolt size	Tightening torque (N·m)
ø16	M1.7 x 0.35	0.15
ø20	M2 x 0.4	0.2
ø25	M2 x 0.4	0.2
ø32	M2 x 0.4	0.2
ø40	M3 x 0.5	0.6
ø50	M3 x 0.5	0.6
ø63	M3 x 0.5	0.6
ø80	M4 x 0.7	1.4

* Be sure to apply thread-locking adhesive.

2-4. Open fingers, and then remove the cam.

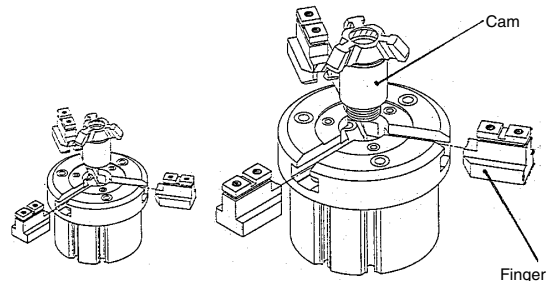

2-5. Loosen the hexagon socket head cap screw, and then remove the guide and body.

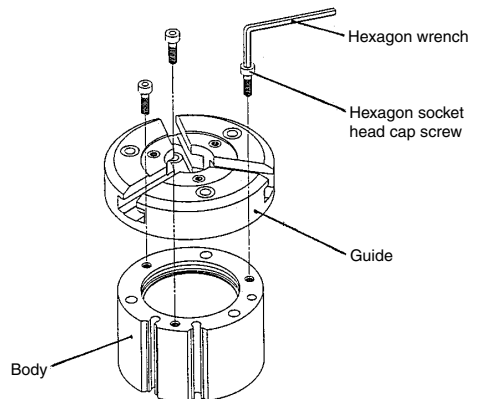

	Applicable bolt size	Hexagon width across flats	Tightening torque (N·m)
ø16	M2.5 x 0.45	2	0.3
ø20	M3 x 0.5	2.5	0.6
ø25	M3 x 0.5	2.5	0.6
ø32	M4 x 0.7	3	1.4
ø40	M4 x 0.7	3	1.4
ø50	M5 x 0.8	4	2.8
ø63	M5 x 0.8	4	2.8
ø80	M6 x 1	5	4.8

* Be sure to apply thread-locking adhesive.

1. Exploded View

Center pusher/Cylinder type

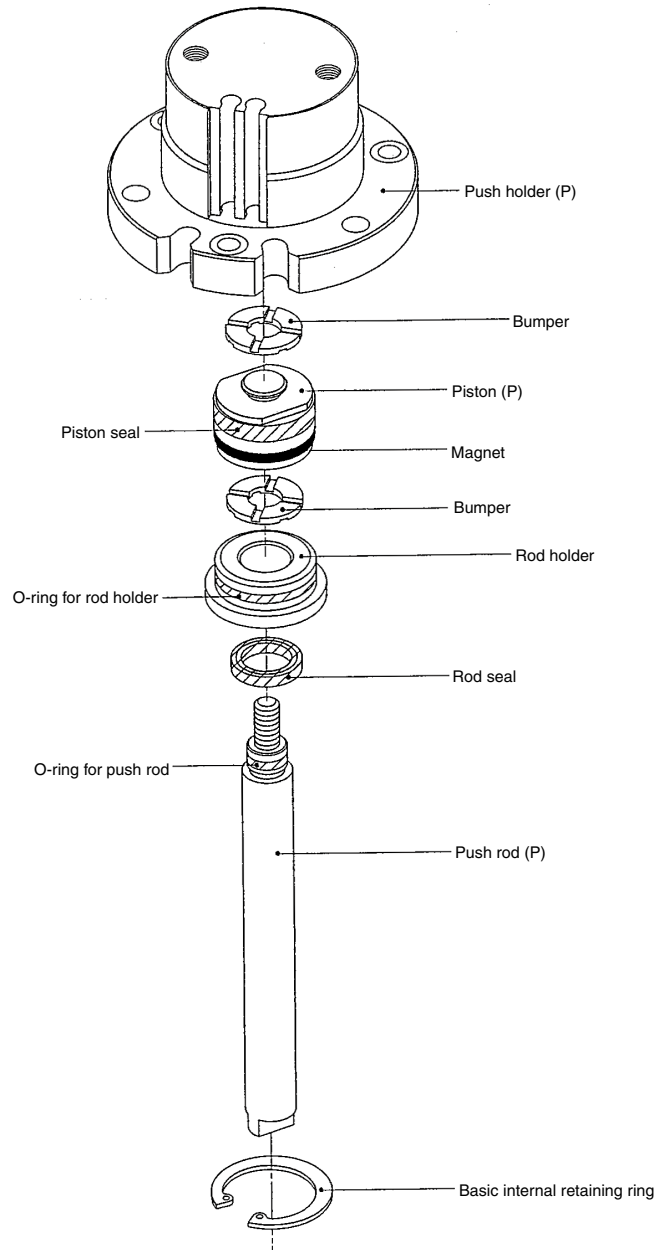

2. Replacement of the Seal

Center pusher/Cylinder type

2-1. Remove the basic internal retaining ring with the specified tool.

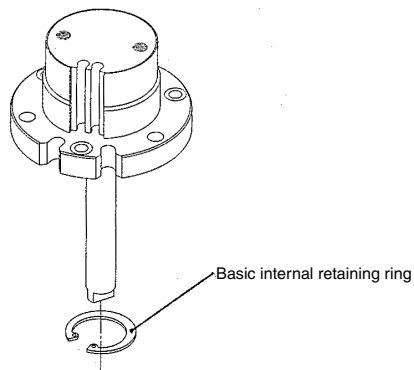

2-2. Take out the push rod assembly, and then replace the seal.

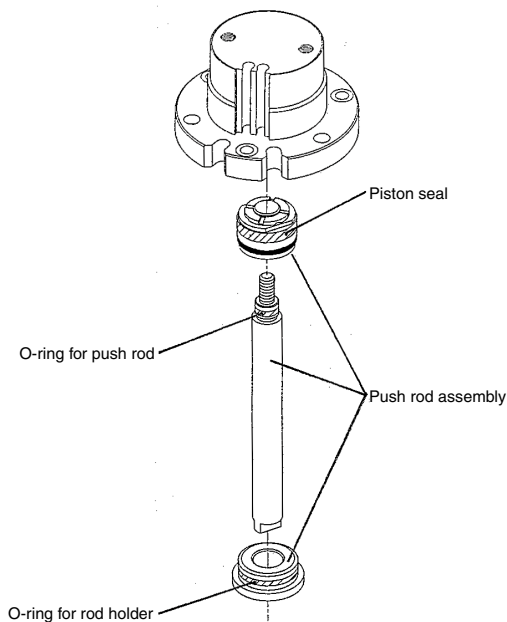

Assembly should be performed by following the removal procedure in reverse.
Refer to the disassembly drawing for the tightening torque for the guide bolt and hexagon socket head set screws.
This product uses a specialized grease. Please contact SMC for details.

1. Exploded View

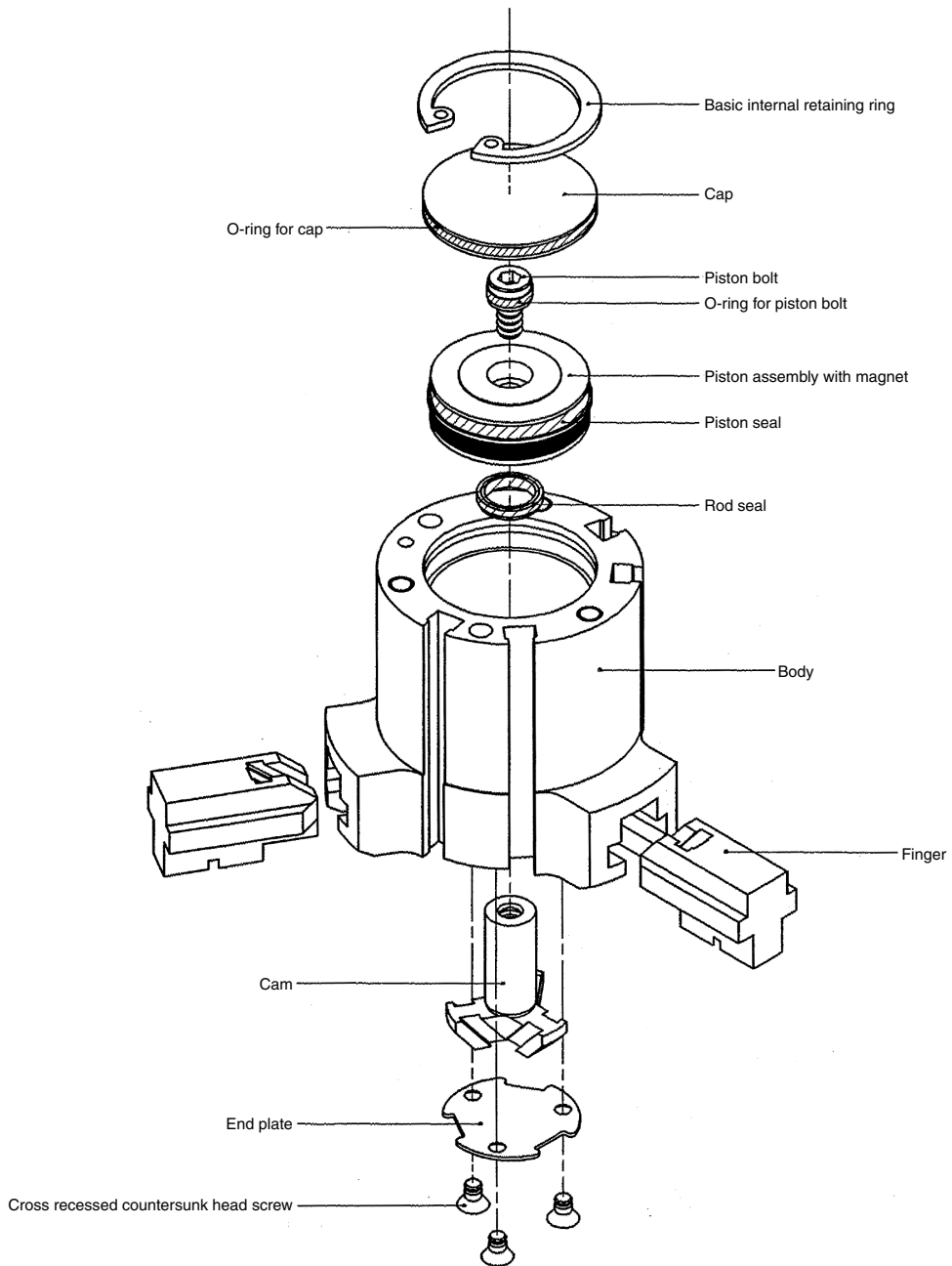

MHSL3 Series Replacement Procedure for Seals 2

2. Replacement of the Seal

2-1. Remove the basic internal retaining ring with the specified tool, and then remove the cap.

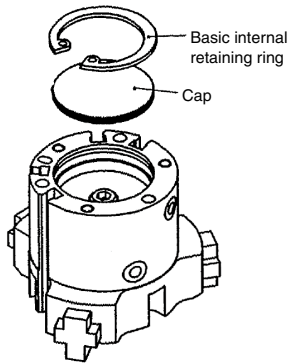

2-2. Remove the piston bolt.

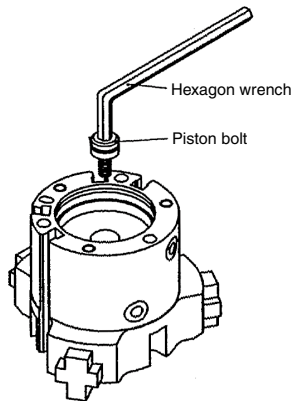

	Applicable bolts	Hexagon width across flats	Tightening torque (N·m)
ø16	M3 x 0.5	2.5	0.6
ø20	M3 x 0.5	2.5	0.6
ø25	M4 x 0.7	3	1.4
ø32	M5 x 0.8	4	5.1
ø40	M5 x 0.8	4	5.1
ø50	M6 x 1	5	8.6
ø63	M8 x 1	6	21.6
ø80	M10 x 1.5	8	24.0
ø100	M12 x 1.75	10	42.2
ø125	M14 x 1.2	12	67.7

* Be sure to apply thread-locking adhesive.

Assembly should be performed by following the removal procedure in reverse.

Use a specified grease.

Grease pack part no: MH-G01 (30 g)

2-3. Remove the piston.

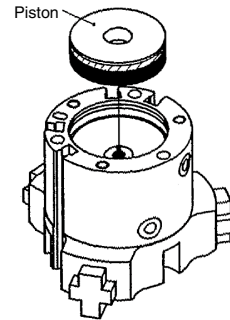

2-4. Unscrew the cross recessed countersunk head screws, and then remove the end plate.

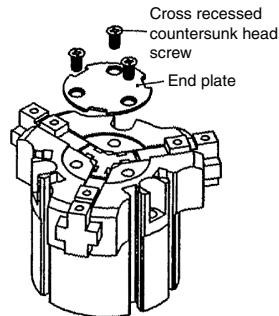

	Bolt size	Tightening torque (N·m)
ø16	M2 x 0.4	0.2
ø20	M2 x 0.4	0.2
ø25	M2 x 0.4	0.2
ø32	M2 x 0.4	0.2
ø40	M3 x 0.5	0.6
ø50	M3 x 0.5	0.6
ø63	M3 x 0.5	0.6
ø80	M4 x 0.7	1.4
ø100	M4 x 0.7	1.4
ø125	M4 x 0.7	1.4

* Be sure to apply thread-locking adhesive.

2-5. Open fingers, and then remove the cam.

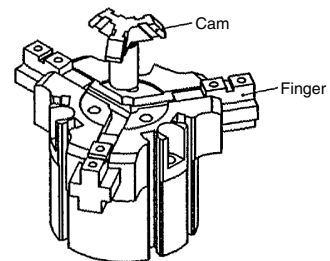

2-6. Replace each seal.

MHC2 Series Replacement Procedure for Seals 1

1. Exploded View

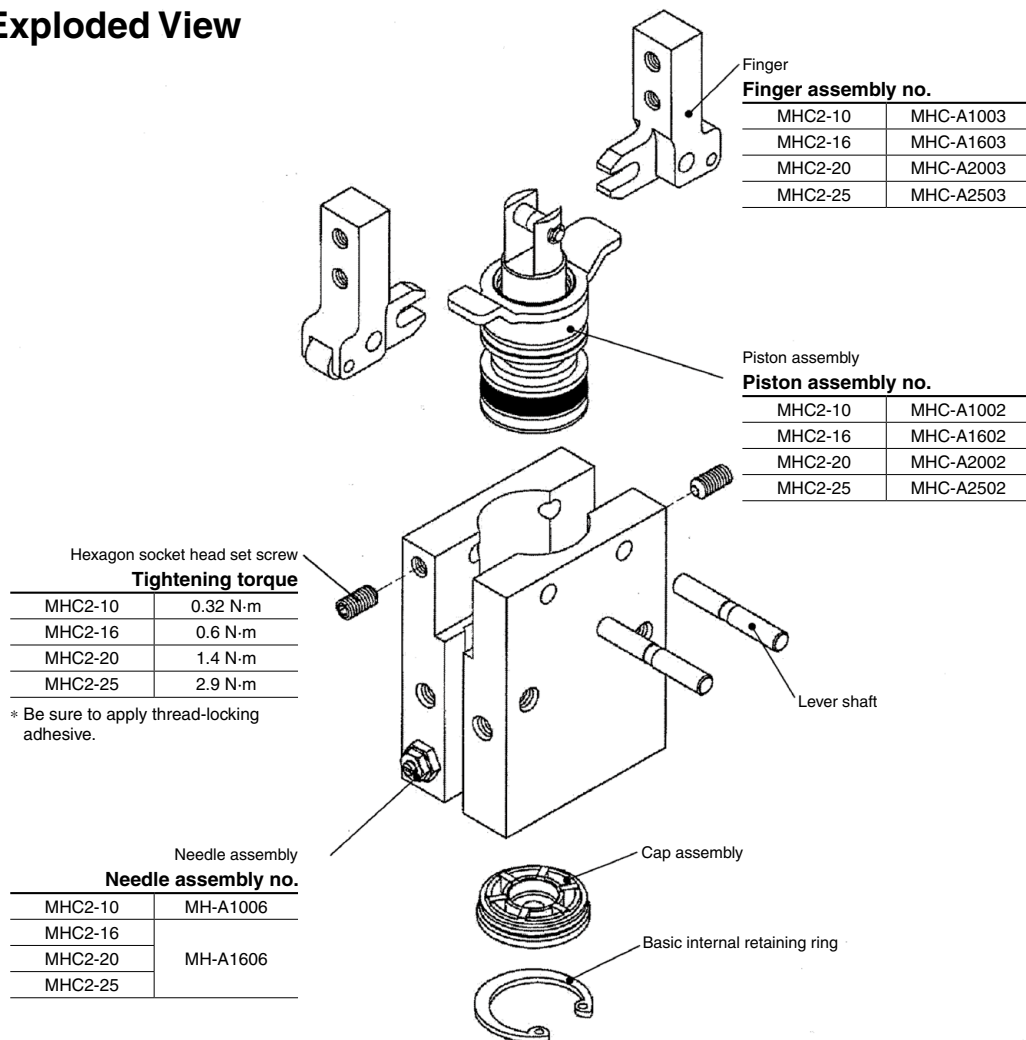

* For the single acting normally open type, there is a spring that goes between the cap assembly and the piston assembly.

2. Replacement of the Seal

2-1. Loosen the hexagon socket set screw, pull out the lever shaft, and then remove the finger.

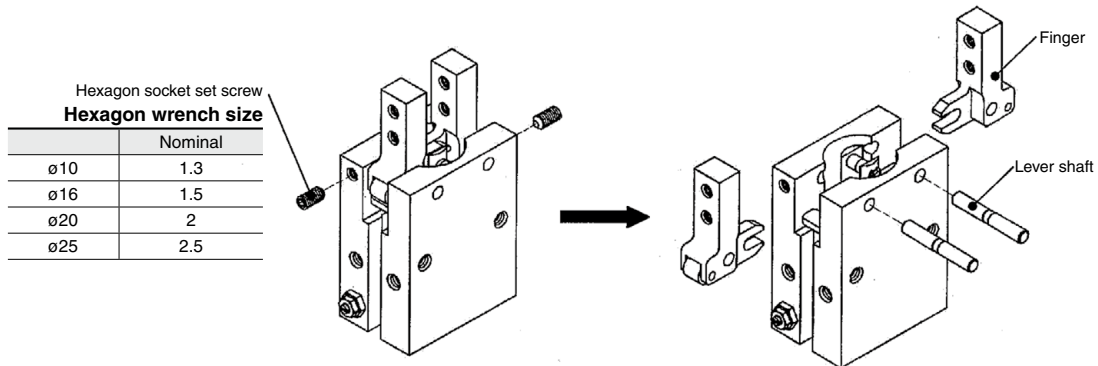

2-2. Take out the piston assembly, and then remove the E retaining ring with the specified tool.

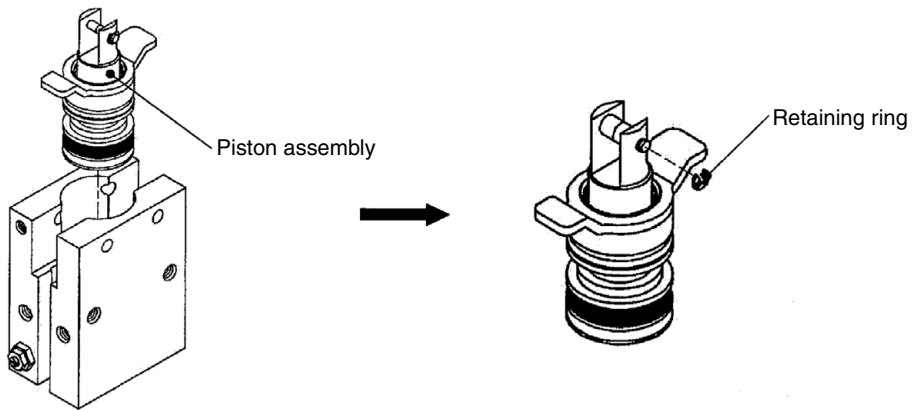

2-3. Remove the center pin, center roller, and piston B assembly, and then replace the seal.

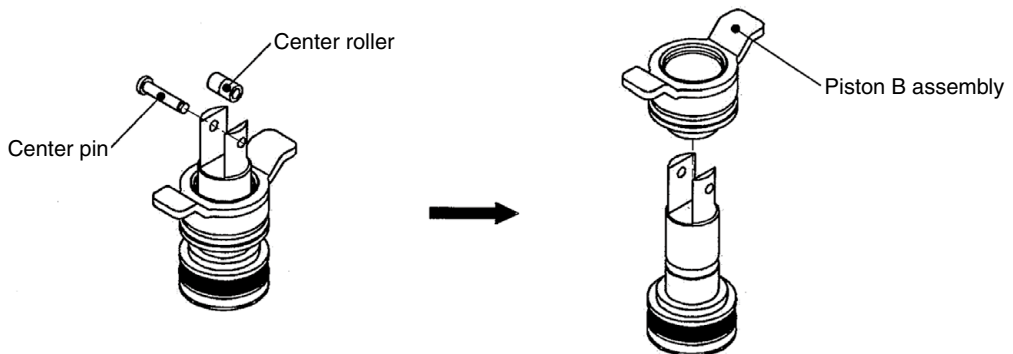

- Assembly should be performed by following the removal procedure in reverse.
- Refer to the disassembly drawing for the tightening torque for the hexagon socket set screws.
- Use a specified grease. **Grease pack part no: GR-S-010** (10 g)

MHY2 Series Replacement Procedure for Seals 1

1. Exploded View

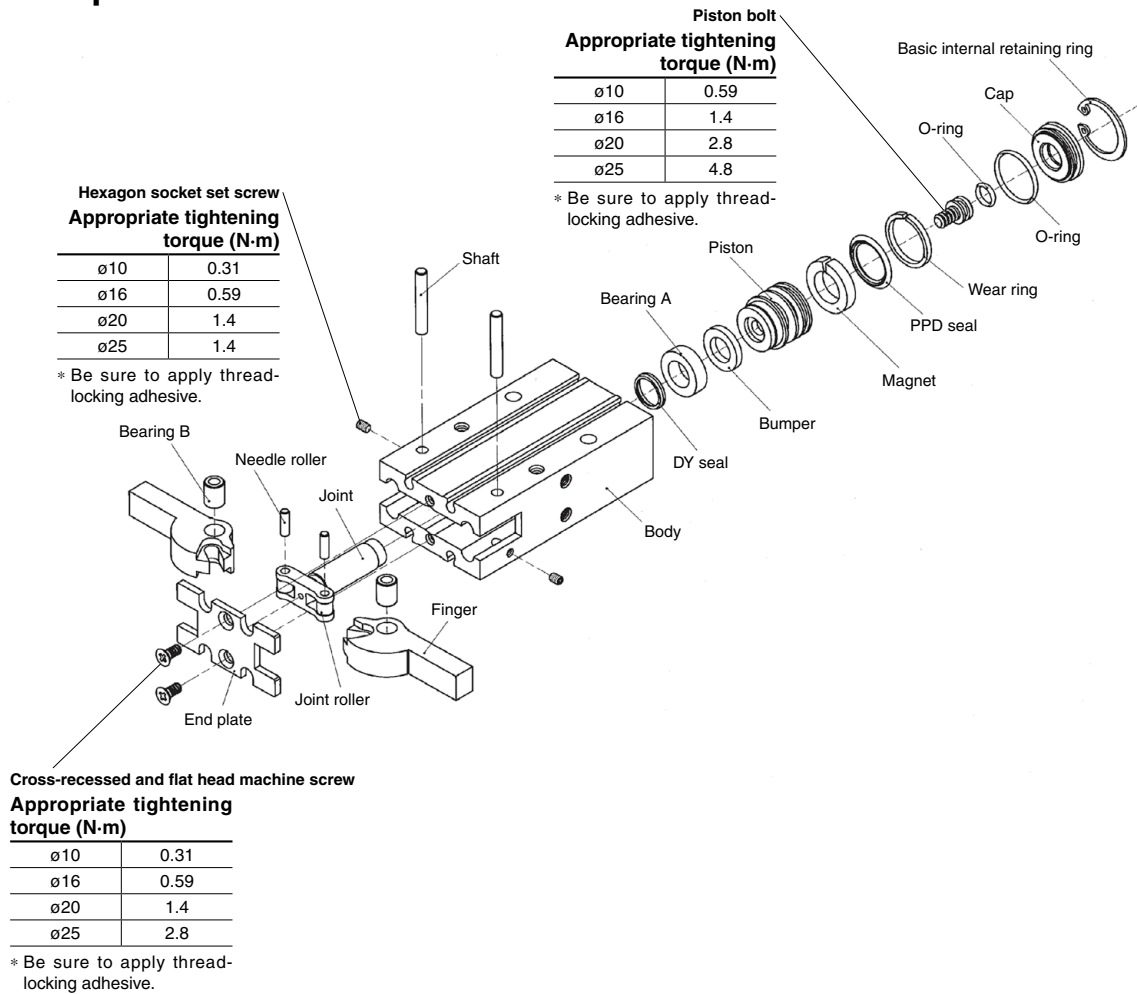

Cross-recessed and flat head machine screw

Appropriate tightening torque (N-m)

ø10	0.31
ø16	0.59
ø20	1.4
ø25	2.8

* Be sure to apply thread-locking adhesive.

MHY2 Series Replacement Procedure for Seals 2

2. Piston Seal and O-ring Replacement

2-1. Remove the basic internal retaining ring with the specified tool, then remove the cap.

2-2. Loosen the piston bolt (piston) with a hexagon wrench.

2-3. Take out the piston assembly, and then replace the seal and the O-ring.

· Assembly should be performed by following the removal procedure in reverse.

Confirm that the bumper is in the predetermined position.

· Refer to the disassembly drawing for the tightening torque for the piston bolt.

· Use a specified grease. **Grease pack part no: MH-G04 (30 g)**

	Hexagon width across flats
ø10	2
ø16	3
ø20	4
ø25	5

ø10

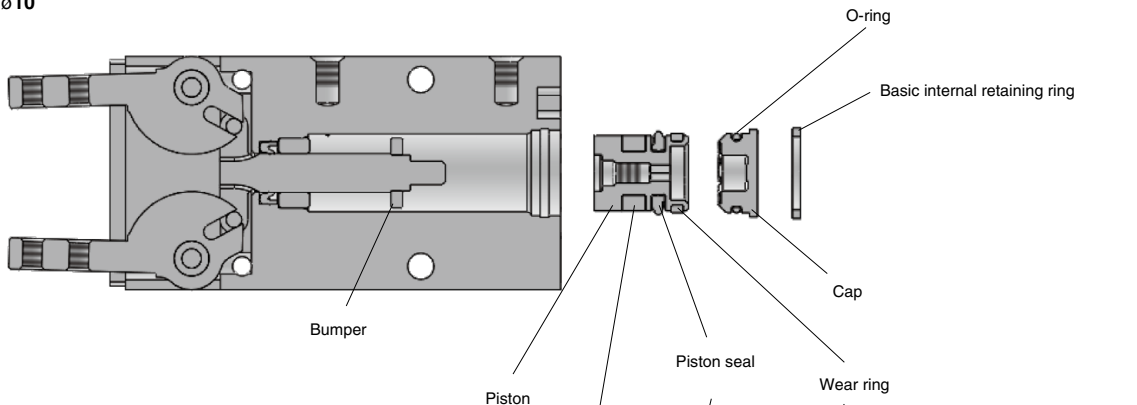

ø16 to ø25

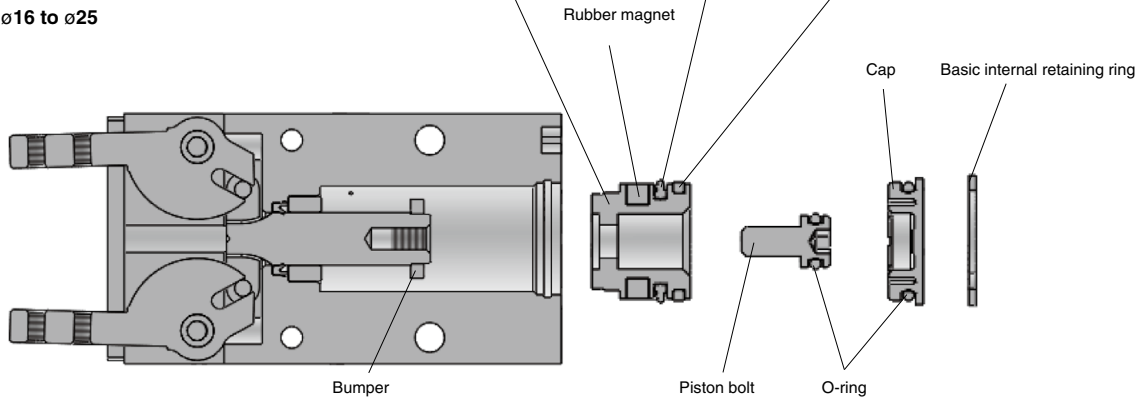

Actuators
 Rotary Actuators
 Air Grippers
 Modular F.R.L.
 Pressure Control Equipment
 Air Preparation
 Equipment
 Industrial Filters
 Replacement
 Procedure
 Actuators
 Rotary Actuators
 Air Grippers
 Modular F.R.L.
 Pressure Control Equipment
 Air Preparation Equipment
 Industrial Filters

MHY2 Series Replacement Procedure for Seals 3

3. Replacement of the Rod Seal

3-1. Take out the piston assembly in the same manner as when replacing the piston seal.

3-2. Unscrew the cross recessed countersunk head screws, and then remove the end plate.

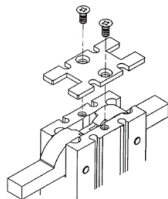

3-3. Loosen the hexagon socket head set screw with a hexagon wrench.

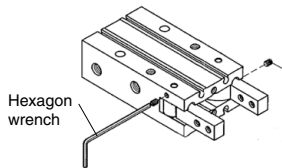

	Hexagon width across flats
ø10	2
ø16	3
ø20	4
ø25	5

3-4. Take out the shaft, and then remove the finger.

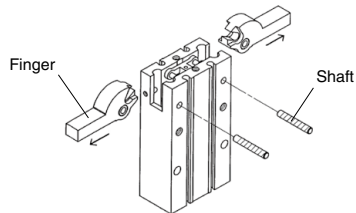

3-5. Pull the joint out.

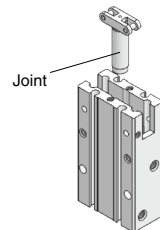

3-6. Replace the rod seal.

Pay attention to the orientation. (Refer to the cross section drawing.)

- Assembly should be performed by following the removal procedure in reverse.
- After inserting the joint, mount the bumper in the predetermined position.
- Refer to the exploded view for the piston bolt (piston) and hexagon socket head set screw tightening torques.
- Use a specified grease.

Grease pack part no: MH-G04 (30 g)

