

Clamp Cylinder Slim Type

C(L)KG/C(L)KP-X2095 Series

ø25, ø32, ø40

The smallest class of clamp cylinder in the world

■ **ø25** is available

Weight **380 g** Length **186.7 mm**
(ø25, 50 stroke without speed controller or auto switch.)

■ **Comparison with current model**

Weight reduced by up to **48%**, total length reduced by **18%**

	Weight (kg)	Length (mm)
Clamp Cylinder CKG-X2095	0.67 (1.31)	146.7 + Stroke (192 + Stroke)
Clamp Cylinder with Lock CLKP-F-X2095	0.97 (1.70)	182.2 + Stroke (236 + Stroke)

Comparison with ø40, 50 stroke with double knuckle joint and speed controller.
 The values in the () are for current model.

Compact auto switch (D-P3DWA)

Magnetic field resistant 2-color indicator solid state auto switch

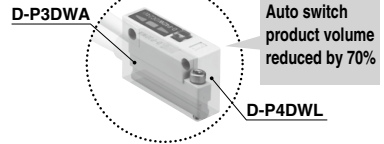

The auto switch mounting position is available from 3 directions.

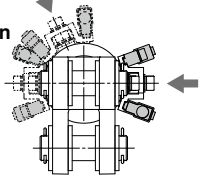

Clamp Cylinder
CK□-X2095

Clevis width

“Clevis width”
“a, b dimensions”
have common interchangeability with all three sizes, ø25 to ø40.

Clamp Cylinder
with Lock
CLK□-X2095

Setting part no. for the model with speed controller. Reduction in selecting and ordering labor.

Variations

Model	Type		Series	Bore size (mm)	Stroke (mm)	Clevis width	End bracket	Option
Clamp Cylinder	Built-in standard magnet type	D-P3DWA	CKG	25, 32, 40	50, 75, 100 125, 150	A: 9 mm B: 12 mm	Double knuckle joint	Speed controllers with One-touch fittings (Both sides)
	Built-in strong magnet type	D-P4DW						
Clamp Cylinder with Lock	Built-in standard magnet type	D-P7	CKP					
	Built-in strong magnet type	D-P3DWA	CLKG					
		D-P4DW	CLKP					

Clamp Cylinder

Slim Type

CKG/CKP-X2095 Series

ø25, ø32, ø40

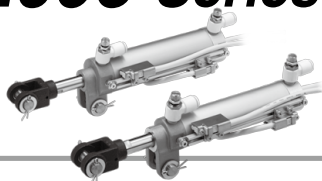

How to Order

Built-in standard magnet type with AC magnetic field resistant auto switch

CKG **B** **32** - **50** **Y** **S** - **P3DWASC** - **X2095**

Built-in strong magnet type with magnetic field resistant auto switch

CKP **B** **32** - **50** **Y** **S** - **P79WSE** - **X2095**

Clevis width

A	9 mm
B	12 mm

* Clevis width symbol

For A: Clevis width B (12 mm) plus two 1.6 mm washers, making the clevis width 9 mm.

Accessories in the form of pins/flat washers (4 pcs./cotter pins (2 pcs.) are included (but not assembled).

For B: Accessories in the form of pins/flat washers (2 pcs./cotter pins (2 pcs.) are included (but not assembled).

Bore size

25	25 mm
32	32 mm
40	40 mm

Cylinder stroke

Bore size	Standard stroke
ø25 to ø40	50, 75, 100, 125, 150

End bracket

Y	Double knuckle joint
----------	----------------------

* Clevis width symbol

For A: Clevis width B (12 mm) plus two 1.6 mm washers, making the clevis width 9 mm.

Accessories in the form of pins/flat washers (4 pcs./cotter pins (2 pcs.) are included (but not assembled).

For B: Accessories in the form of pins/flat washers (2 pcs./cotter pins (2 pcs.) are included (but not assembled).

Option

Nil	None
S	With speed controller

* Speed controllers (2 pcs.) are shipped together (but not assembled).

Number of auto switches

Nil	2 pcs.
S	1 pc.
n	"n" pcs. (n = 3, 4, 5--n)

Slim Type

Auto switch

For applicable auto switch model, refer to the **Table 1**.

Nil	Without auto switch (built-in magnet) Without switch mounting rail
P	Without auto switch (built-in magnet) With switch mounting rail

* Auto switch rails are shipped assembled.

* Auto switches are shipped together (but not assembled).

* Auto switch rails are shipped with mounting locations attached on the right side, as you look from the rod end.

Built-in Standard (Strong) Magnet Cylinder Part No.

- Built-in standard (strong) magnet type without auto switch and switch mounting rail
Symbol for the auto switch type is "Nil" as shown below.
CKG: (Example) CKGA32-50Y-X2095
CKP: (Example) CKPA32-50Y-X2095
- Built-in standard (strong) magnet type without auto switch, with switch mounting rail
Symbol for the auto switch type is "P" as shown below.
CKG: (Example) CKGA32-50Y-P-X2095
CKP: (Example) CKPA32-50Y-P-X2095

Table 1

Applicable Magnetic Field Resistant Auto Switches/Refer to pages 1341 to 1435 for detailed auto switch specifications.

Applicable cylinder series	Type	Auto switch model	Applicable magnetic field	Electrical entry	Indicator light	Wiring (Pin no. in use)	Load voltage	Lead wire length	Applicable load
CKG series	Solid state auto switch	P3DWASC	AC magnetic field (Single-phase AC welding magnetic field)	Pre-wired connector	2-color indicator	2-wire (3-4)	24 VDC	0.3 m	Relay, PLC (Note 1)
		2-wire (1-4)							
		P3DWA		Grommet		2-wire		0.5 m	
		P3DWAL				3 m			
		P3DWAZ		Pre-wired connector	2-wire (3-4)	24 VDC		0.3 m	
		P4DWSE			2-wire (1-4)			3 m	
		P4DWL		Grommet	2-wire	5 m			
		P4DWZ			3 m				
CKP series	Reed auto switch	P79WSE	DC/AC magnetic field	Pre-wired connector	2-color indicator	2-wire (1-4)	24 VDC	0.3 m	
		2-wire (3-4)				0.5 m			
		P74GSC		Grommet	1-color indicator	2-wire		0.3 m	
		P74L						3 m	
		P74Z		Pre-wired connector	2-wire	24 VDC		5 m	
		100 VDC						5 m	

Note 1) PLC: Programmable Logic Controller

Note 2) There are other applicable auto switches other than the listed above. For details, refer to page 505.

Note 3) Refer to page 506 and 507 when ordering the auto switch mounting bracket assembly or switch mounting rail assembly.

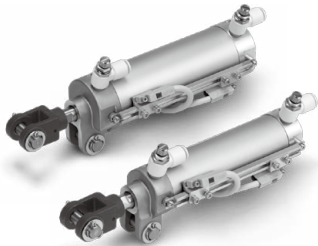

Symbol

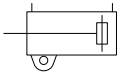

Standard Stroke

Bore size (mm)	Standard stroke (mm)
25, 32, 40	50, 75, 100, 125, 150

Refer to pages 505 to 507 for cylinders with auto switches.

- Auto Switch Proper Mounting Position (Detection at Stroke End) and Its Mounting Height
- Minimum Stroke for Auto Switch Mounting
- Operating Range
- How to Mount and Move the Auto Switch
- Auto Switch Rail Assembly Part No.

Specifications

Bore size (mm)	25	32	40
Fluid	Air		
Proof pressure	1.5 MPa		
Maximum operating pressure	1.0 MPa		
Minimum operating pressure	0.05 MPa		
Ambient and fluid temperature	-10°C to 60°C		
Piston speed	50 to 500 mm/s		
Cushion	Rubber bumper		
Lubrication	Non-lube		
Stroke length tolerance ^{Note 1)}	+1.0 0		
Mounting ^{Note 2)}	Double clevis		

* Refer to the CK1 series on pages 435 to 460 for "Safety Instructions" and "Specific Product Precautions".

Note 1) Stroke length tolerance does not include the amount of bumper change.

Note 2) Clevis pin, cotter pin, flat washer are equipped as a standard.

Clevis width	9 mm ^{Note)}	CKGA/CKPA
	12 mm	CKGB/CKPB

Note) 1.6 mm thick washer attached to 12 mm.

Option

Symbol	Description	Part no.
S	Flame resistant speed controllers with One-touch fittings	AS2201F-01-06W2 Port size: R1/8 Applicable tubing O.D. mm: ø6 Control method: Meter-out type

Theoretical Output

Bore size (mm)	Rod size (mm)	Operating direction	Piston area (mm ²)	Operating pressure (MPa)			
				0.3	0.4	0.5	0.6
				Unit: N			
25	12	OUT	491	147	196	246	295
		IN	378	113	151	189	227
32	12	OUT	804	241	322	402	482
		IN	691	207	276	346	415
40	12	OUT	1260	378	504	630	756
		IN	1147	344	459	574	688

Weight

(Basic weight includes the double knuckle joint and auto switch rail at 0 stroke.)

Bore size (mm)		25	32	40
CKG□ series	Basic weight (0 mm stroke)	0.30	0.37	0.51
	Additional weight per 25 mm stroke	0.04	0.05	0.06
CKP□ series	Basic weight (0 mm stroke)	0.31	0.38	0.53
	Additional weight per 25 mm stroke	0.04	0.05	0.06
Speed controller		0.04	0.04	0.04

Note) The above values do not include the weight of the auto switch and auto switch mounting bracket.

Calculation Example) **CKG□32-100YS-P-X2095**

- Basic weight:.....0.37 (ø32)
 - Additional weight:.....0.05/25 stroke
 - Speed controller:.....0.04 (S)
 - Cylinder stroke:.....100 stroke
- 0.37 + 0.05 × 100/25 + 0.04 = 0.61 kg

CKG/CKP-X2095 Series

Construction: CKG□/CKP□25, 32, 40

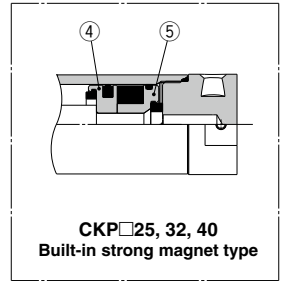
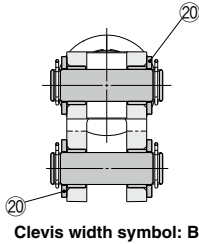
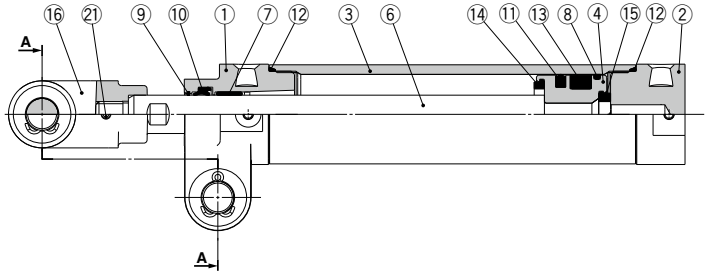
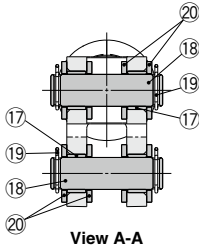

Component Parts

No.	Description	Material	Qty.	Note
1	Rod cover	Aluminum alloy	1	Trivalent chromated
2	Head cover	Aluminum alloy	1	Hard anodized
3	Cylinder tube	Aluminum alloy	1	Hard anodized
4	Piston	Aluminum alloy	1	Trivalent chromated: CKG□
	PistonA	Aluminum alloy		Trivalent chromated: CKP□
5	PistonB	Aluminum alloy	1	Trivalent chromated: CKP□
6	Piston rod	Stainless steel	1	Hard chrome plated: ø25
		Structural steel		Hard chrome plated: ø32, ø40
7	Bushing	Oil-impregnated sintered alloy	1	
8	Wear ring	Resin	1	
9	Coil scraper	Bronze	1	
10	Rod seal	NBR	1	
11	Piston seal	NBR	1	
12	Tube gasket	NBR	2	

No.	Description	Material	Qty.	Note
13	Magnet	—	1	
14	Bumper	Urethane rubber	1	Rod end
15	Bumper	Urethane rubber	1	Head end
16	Double knuckle joint	Cast iron	1	Manganese phosphate coating
17	Clevis bushing	Steel strip + PTFE	4	
18	Clevis pin/Knuckle pin	Structural steel	2	
19	Cotter pin	Steel wire	4	Zinc trivalent chromated
				8
20	Flat washer	Steel strip	4	Nickel plated: Clevis width symbol B
				1
21	Spring pin	Tool steel	1	

Replacement Parts/Seal Kit

Bore size (mm)	Order no.	Note
25	CKA25-X2095-PS	Set of nos. above ⑩, ⑪, ⑫
32	CKA32-X2095-PS	
40	CKA40-X2095-PS	

Dimensions

CKG□/CKP□25, 32, 40

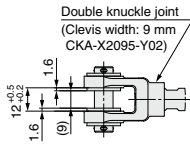

CK□A25, 32, 40
(Clevis width symbol: A)

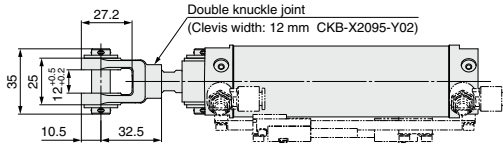

CK□B25, 32, 40
(Clevis width symbol: B)

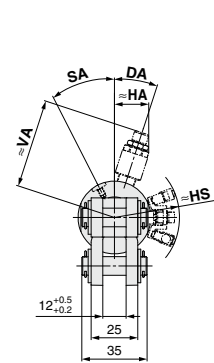

CK□B25, 32, 40
(Clevis width symbol: B)

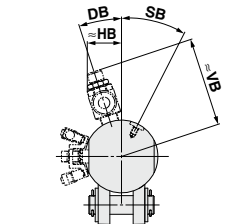
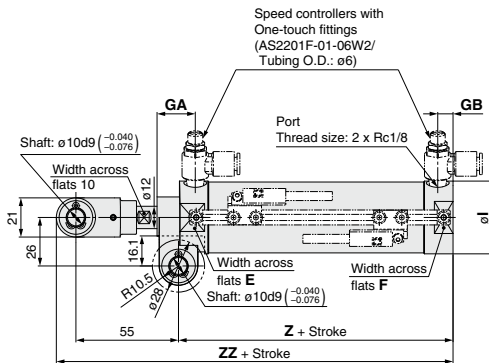

CK□B25, 32, 40
(Clevis width symbol: B)

CK□B25, 32, 40
(Clevis width symbol: B)

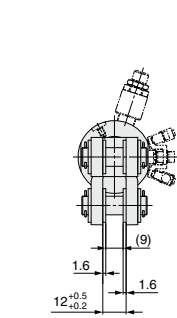

CK□A25, 32, 40
(Clevis width symbol: A)

Pin (For Clevis/Double Knuckle Joint)

Part no.	Applicable cylinder
CKA-X2095-P02	CK□A25 to 40 series CLK□A25 to 40 series
CKB-X2095-P02	CK□B25 to 40 series CLK□B25 to 40 series

* Cotter pins and flat washers are provided as a standard.

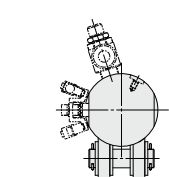

CK□A25, 32, 40
(Clevis width symbol: A)

Symbol Bore size	DA	DB	E	F	GA	GB	HA		HB		HS	øI	SA	SB	VA		VB		Z	ZZ
							MAX.	MIN.	MAX.	MIN.					MAX.	MIN.	MAX.	MIN.		
							(mm)													
25	14°	14°	29.5	28.5	20.5	7.5	15.6	14.9	15.6	14.9	31.9	32	25°	25°	49.3	44.3	49.3	44.3	71.2	136.7
32	18°	18°	36	35	20.5	8.2	19.5	18.3	19.5	18.3	35.7	39	27°	27°	52.8	47.8	52.8	47.8	72.2	137.7
40	21°	21°	44.5	43.5	20.5	11	24	22.2	24	22.2	39.6	48	22°	22°	57.3	52.3	57.3	52.3	81.2	146.7

Clamp Cylinder with Lock Slim Type

CLKG/CLKP-X2095 Series

ø25, ø32, ø40



Unlock-port separate piping type is available.
Refer to page 508.

How to Order

Built-in standard magnet type
with AC magnetic field resistant
auto switch

CLKG **B** 32 - 50 Y S - B - P3DWASC - X2095

Built-in strong magnet type
with magnetic field resistant
auto switch

CLKP **B** 32 - 50 Y S - B - P79WSE - X2095

Clevis width

A	9 mm
B	12 mm

* Clevis width symbol

For A: Clevis width B (12 mm) plus two 1.6 mm washers, making the clevis width 9 mm.

Accessories in the form of pins/flat washers (4 pcs.)/cotter pins (2 pcs.) are included (but not assembled).

For B: Accessories in the form of pins/flat washers (2 pcs.)/cotter pins (2 pcs.) are included (but not assembled).

Bore size

25	25 mm
32	32 mm
40	40 mm

Cylinder stroke

Bore size	Standard stroke
ø25 to ø40	50, 75, 100, 125, 150

End bracket

Y	Double knuckle joint
----------	----------------------

* Clevis width symbol

For A: Clevis width B (12 mm) plus two 1.6 mm washers, making the clevis width 9 mm.

Accessories in the form of pins/flat washers (4 pcs.)/cotter pins (2 pcs.) are included (but not assembled).

For B: Accessories in the form of pins/flat washers (2 pcs.)/cotter pins (2 pcs.) are included (but not assembled).

Option

Nil	None
S	With speed controller

* Speed controllers (2 pcs.) are shipped together (but not assembled).

Locking direction

B	Retraction locking
F	Extension locking

Number of auto switches

Nil	2 pcs.
S	1 pc.
n	"n" pcs. (n = 3, 4, 5...n)

Slim Type

Auto switch

For applicable auto switch model, refer to the [Table 1](#).

Nil	Without auto switch (built-in magnet) Without switch mounting rail
P	Without auto switch (built-in magnet) With switch mounting rail

* Auto switch rails are shipped assembled.

* Auto switches are shipped together (but not assembled).

* Auto switch rails are shipped with mounting locations attached on the right side, as you look from the rod end.

Built-in Standard (Strong) Magnet Cylinder Part No.

- Built-in standard (strong) magnet type without auto switch and switch mounting rail
Symbol for the auto switch type is "Nil" as shown below.
CLKG: (Example) CLKGA32-50Y-B-X2095
CLKP: (Example) CLKPA32-50Y-B-X2095
- Built-in standard (strong) magnet type without auto switch, with switch mounting rail
Symbol for the auto switch type is "P" as shown below.
CLKG: (Example) CLKGA32-50Y-B-P-X2095
CLKP: (Example) CLKPA32-50Y-B-P-X2095

Table 1

Applicable Magnetic Field Resistant Auto Switches/Refer to pages 1341 to 1435 for detailed auto switch specifications.

Applicable cylinder series	Type	Auto switch model	Applicable magnetic field	Electrical entry	Indicator light	Wiring (Pin no. in use)	Load voltage	Lead wire length	Applicable load
CLKG series	Solid state auto switch	P3DWASC	AC magnetic field (Single-phase AC welding magnetic field)	Pre-wired connector	2-color indicator	2-wire (3-4)	24 VDC	0.3 m	Relay, PLC (Note 1)
		2-wire (1-4)							
		P3DWA		Grommet		2-wire		0.5 m	
		P3DWAL				3 m			
		P3DWAZ		Pre-wired connector	2-wire (3-4)	24 VDC		0.3 m	
		P4DWSC			2-wire (1-4)			3 m	
		P4DWSE		Grommet	2-wire	5 m			
		P4DWL			3 m				
P4DWZ	5 m								
CLKP series	Reed auto switch	P79WSE	DC/AC magnetic field	Pre-wired connector	2-color indicator	2-wire (1-4)	24 VDC	0.3 m	
		1-color indicator			2-wire (3-4)	0.5 m			
		P74-376		Grommet	2-wire	0.3 m			
		P74GSC			3 m				
		P74L			5 m				
P74Z	24 VDC	100 VAC	5 m						

Note 1) PLC: Programmable Logic Controller

Note 2) There are other applicable auto switches other than the listed above. For details, refer to page 505.

Note 3) Refer to page 506 and 507 when ordering the auto switch mounting bracket assembly or switch mounting rail assembly.

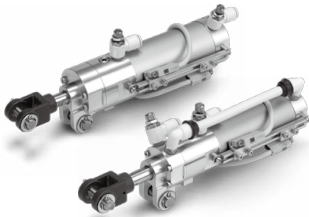

Symbol



Retraction locking type



Extension locking type

Standard Stroke

Bore size (mm)	Standard stroke (mm)
25, 32, 40	50, 75, 100, 125, 150

Refer to pages 505 to 507 for cylinders with auto switches.

- Auto Switch Proper Mounting Position (Detection at Stroke End) and Its Mounting Height
- Minimum Stroke for Auto Switch Mounting
- Operating Range
- How to Mount and Move the Auto Switch
- Auto Switch Rail Assembly Part No.

Manually Unlocking

Warning

- ① Never remove the protective cover under any circumstances.

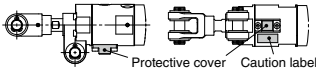

- ② After confirming safety, operate the manual release following the steps shown below.

Carefully confirm that no one is inside the load movement range, etc., and that there is no danger even if the load moves suddenly.

Manually unlocking (ø25 to ø40)

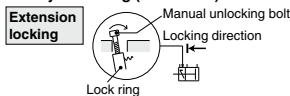

- 1) For ø25, remove the dust cover. For ø32 and ø40, remove the plug.
- 2) Screw a manual unlocking bolt (a current bolt of M3 x 0.5 x 15L) into the lock ring threads as shown above, and lightly push the bolt in the direction of the arrow (head side) to unlock.

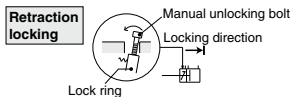

- 1) For ø25, remove the dust cover. For ø32 and ø40, remove the plug.
- 2) Screw a manual unlocking bolt (a current bolt of M3 x 0.5 x 15L) into the lock ring threads as shown above, and lightly push the bolt in the direction of the arrow (rod side) to unlock.

Specifications

Bore size	25	32	40
Action	Double acting, Single rod		
Fluid	Air		
Proof pressure	1.5 MPa		
Maximum operating pressure	1.0 MPa		
Minimum operating pressure	0.2 MPa		
Locking action	Spring locking		
Locking pressure	0.05 MPa		
Locking direction	One direction (Retraction, Extension)		
Lock holding force N (Max. static load)	Equivalent to 0.5 MPa		
	245	402	629
Lock application	Drop prevention, Position holding		
Ambient and fluid temperature	-10°C to 60°C		
Lubrication	Non-tube		
Piston speed	50 to 500 mm/s		
Stroke length tolerance (Note 1)	+1.0 0		
Cushion	Rubber bumper		
Mounting (Note 2)	Double clevis		

* Refer to the CLK2 series on pages 461 to 490 for "Safety Instructions" and "Specific Product Precautions".
Note 1) Stroke length tolerance does not include the amount of bumper change.
Note 2) Clevis pin, cotter pin, flat washer are equipped as a standard.

Clevis width	9 mm (Note)	CLKGA/CLKPA
	12 mm	CLKGB/CLKPB

Note) 1.6 mm thick washer attached to 12 mm.

Option

Symbol	Description	Part no.
S	Flame resistant speed controllers with One-touch fittings	AS2201F-01-06W2 Port size: R1/8 Applicable tubing O.D. mm: ø6 Control method: Meter-out type

Theoretical Output

Bore size (mm)	Rod size (mm)	Operating direction	Piston area (mm ²)	Operating pressure (MPa)			
				0.3	0.4	0.5	0.6
25	12	OUT	491	147	196	246	295
		IN	378	113	151	189	227
32	12	OUT	804	241	322	402	482
		IN	691	207	276	346	415
40	12	OUT	1260	378	504	630	756
		IN	1147	344	459	574	688

Unit: N

Weight (Basic weight includes the double knuckle joint and auto switch rail at 0 stroke.)

Bore size (mm)	25	32	40	
	CLKG□ series	B: 0.39 F: 0.40	B: 0.58 F: 0.60	B: 0.76 F: 0.78
CLKP□ series	Basic weight (0 mm stroke)	0.04	0.05	0.06
	Additional weight per 25 mm stroke	0.04	0.05	0.06
Speed controller	0.04	0.04	0.04	

Unit: kg

Note) The above values do not include the weight of the auto switch and auto switch mounting bracket.
Calculation Example) CLKG□32-100YS-B-P-X2095

- Basic weight:0.58 (ø32)
- Additional weight:0.05/25 stroke
- Speed controller:0.04 (S)
- Cylinder stroke:100 stroke

0.58 + 0.05 x 100/25 + 0.04 = 0.82 kg

CLKG/CLKP-X2095 Series

Construction: CLKG□/CLKP□25

Retraction locking (B)

View A-A
Clevis width
symbol: A

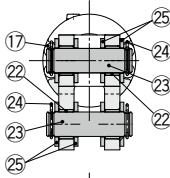

Clevis width
symbol: B

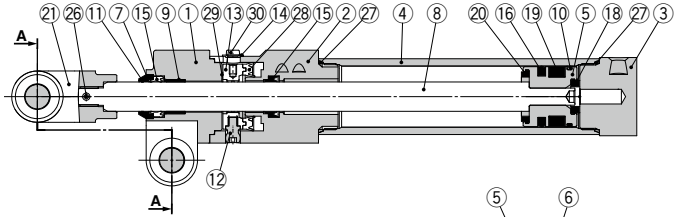
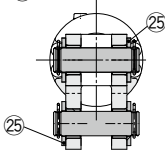

CLKP□25
Built-in strong magnet type

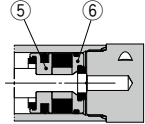

Extension locking (F)

View B-B
Clevis width
symbol: A

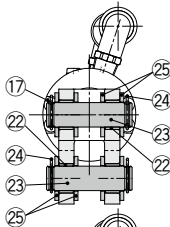

Clevis width
symbol: B

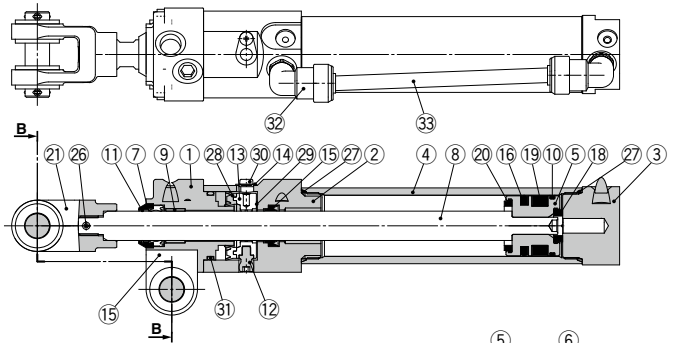
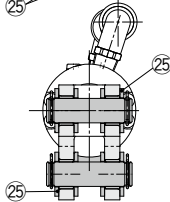

CLKP□25
With strong magnet type

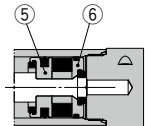

Component Parts

No.	Description	Material	Qty.	Note
1	Rod cover	Aluminum alloy	1	Trivalent chromated
2	Lock body	Aluminum alloy	1	Trivalent chromated
3	Head cover	Aluminum alloy	1	Hard anodized
4	Cylinder tube	Aluminum alloy	1	Hard anodized
5	Piston	Aluminum alloy	1	Trivalent chromated: CLKG□
	PistonA	Aluminum alloy		Trivalent chromated: CLKP□
6	PistonB	Aluminum alloy	1	Trivalent chromated: CLKP□
7	Holder	Brass	1	—
8	Piston rod	Stainless steel	1	Hard chrome plated
9	Bushing	Oil-impregnated sintered alloy	1	—
10	Wear ring	Resin	1	—
11	Coil scraper	Bronze	1	—
12	Pivot	Structural steel	1	Electroless nickel plated
13	Lock ring	Structural steel	1	Zinc trivalent chromated
14	Dust cover	Stainless steel	1	—
15	Rod seal	NBR	2	—
16	Piston seal	NBR	1	—

No.	Description	Material	Qty.	Note
17	Hexagon socket head cap screw	Structural steel	4	Nickel plated
18	Bumper	Urethane rubber	1	—
19	Magnet	—	1	—
20	Bumper	Urethane rubber	1	—
21	Double knuckle joint	Cast iron	1	Manganese phosphate coating
22	Clevis bushing	Resin	4	—
23	Clevis pin/Knuckle pin	Structural steel	2	—
24	Cotter pin	Steel wire	4	Zinc trivalent chromated
25	Flat washer	Steel strip	8	Nickel plated: Clevis width symbol A
			4	Nickel plated: Clevis width symbol B
26	Spring pin	Tool steel	1	—
27	Tube gasket	NBR	2	—
28	Lock ring seal	NBR	1	—
29	Brake spring	Steel wire	2	—
30	Cross recessed round head screw	Structural steel	1	Nickel plated
31	O-ring	NBR	1	—
32	FR One-touch fitting	—	2	Extension locking only
33	FR double layer tube	—	1	Extension locking only

Construction: CLKG□/CLKP□32, 40

Retraction locking (B)

View A-A

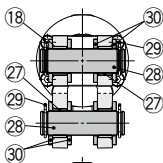
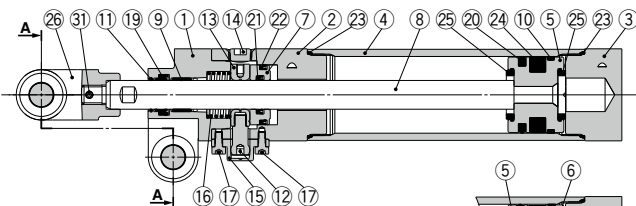
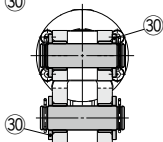
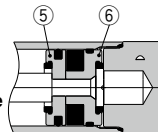
Clevis width
symbol: BCLKP□32, 40
Built-in strong magnet type

Extension locking (F)

View A-A

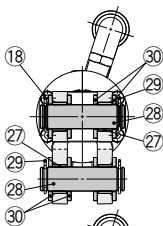
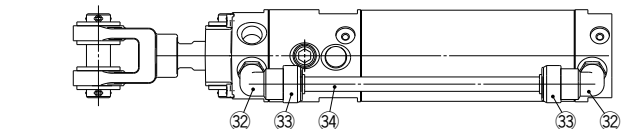
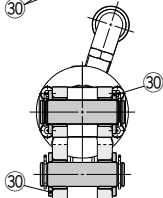
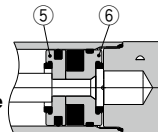
Clevis width
symbol: BCLKP□32, 40
Built-in strong magnet type

Component Parts

No.	Description	Material	Qty.	Note
1	Cover	Aluminum alloy	1	Trivalent chromated
2	Rod cover	Aluminum alloy	1	Hard anodized
3	Head cover	Aluminum alloy	1	Hard anodized
4	Cylinder tube	Aluminum alloy	1	Hard anodized
5	Piston	Aluminum alloy	1	Trivalent chromated: CLKG□
	PistonA	Aluminum alloy		Trivalent chromated: CLKP□
6	PistonB	Aluminum alloy	1	Trivalent chromated: CLKP□
7	Release piston	Aluminum alloy	1	Trivalent chromated
8	Piston rod	Special purpose steel	1	Quenched Hard chrome plated
9	Bushing	Oil-impregnated sintered alloy	1	
10	Wear ring	Resin	1	
11	Coil scraper	Bronze	1	
12	Pivot	Structural steel	1	Electroless nickel plated
13	Lock ring	Structural steel	1	Zinc trivalent chromated
14	Plug	Structural steel	1	Nickel plated
15	Protective cover	Aluminum alloy	1	Hard anodized
16	Brake spring	Steel wire	1	Zinc trivalent chromated
17	Hexagon socket head cap screw	Structural steel	2	Nickel plated

No.	Description	Material	Qty.	Note
18	Hexagon socket head cap screw	Structural steel	4	Nickel plated
19	Rod seal	NBR	1	Retraction locking
20	Piston seal	NBR	1	Extension locking
21	Release piston seal A	NBR	1	
22	Release piston seal B	NBR	1	
23	Tube gasket	NBR	2	
24	Magnet	—	1	
25	Bumper	Urethane rubber	2	
26	Double knuckle joint	Cast iron	1	Manganese phosphate coating
27	Clevis bushing	Steel strip + PTFE	4	
28	Clevis pin/Knuckle pin	Structural steel	2	
29	Cotter pin	Steel wire	4	Zinc trivalent chromated
30	Flat washer	Steel strip	8	Nickel plated: Clevis width symbol A
				Nickel plated: Clevis width symbol B
31	Spring pin	Tool steel	1	
32	FR One-touch fitting	—	2	Extension locking only
33	Spatter cover	—	2	Extension locking only
34	FR double layer tube	—	1	Extension locking only

CLKG/CLKP-X2095 Series

Dimensions

CLKG□/CLKP□25

Extension locking (F)

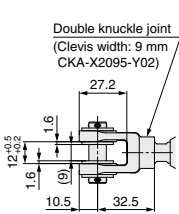

CLK□A25
(Clevis width symbol: A)

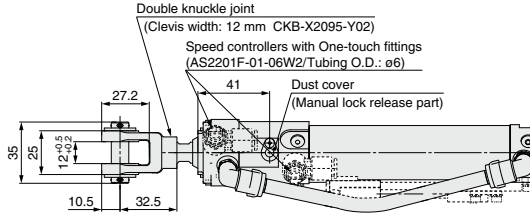

CLK□B25
(Clevis width symbol: B)

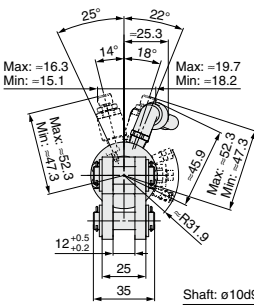

CLK□B25
(Clevis width symbol: B)

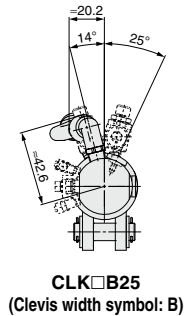
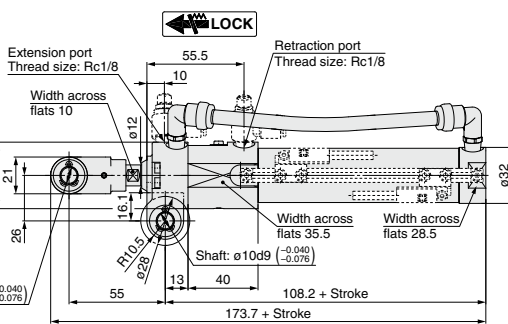

CLK□B25
(Clevis width symbol: B)

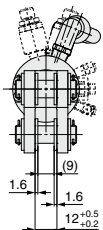

CLK□A25
(Clevis width symbol: A)

Pin (For Clevis/Double Knuckle Joint)

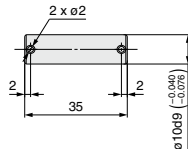

Part no.	Applicable cylinder
CKA-X2095-P02	CK□A25 to 40 series CLK□A25 to 40 series
CKB-X2095-P02	CK□B25 to 40 series CLK□B25 to 40 series

* Cotter pins and flat washers are provided as a standard.

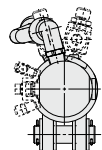

CLK□A25
(Clevis width symbol: A)

Dimensions

CLKG□/CLKP□32

Extension locking (F)

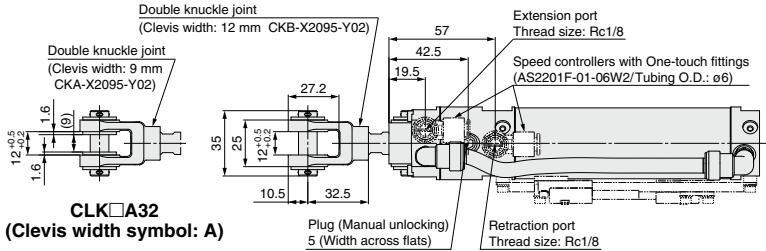

CLK□A32
(Clevis width symbol: A)

CLK□B32
(Clevis width symbol: B)

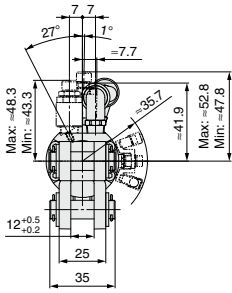

CLK□B32
(Clevis width symbol: B)

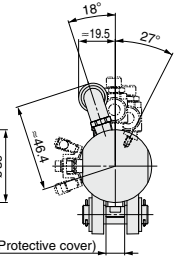
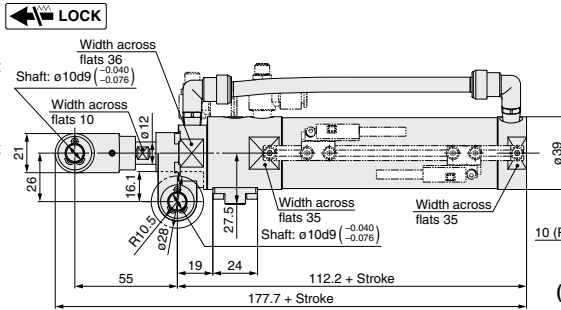

CLK□B32
(Clevis width symbol: B)

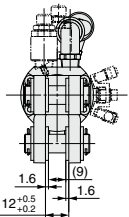

CLK□A32
(Clevis width symbol: A)

Pin (For Clevis/Double Knuckle Joint)

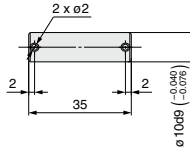

Part no.	Applicable cylinder
CKA-X2095-P02	CK□A25 to 40 series CLK□A25 to 40 series
CKB-X2095-P02	CK□B25 to 40 series CLK□B25 to 40 series

* Cotter pins and flat washers are provided as a standard.

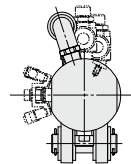

CLK□A32
(Clevis width symbol: A)

CLKG/CLKP-X2095 Series

Dimensions

CLKG□/CLKP□40

Extension locking (F)

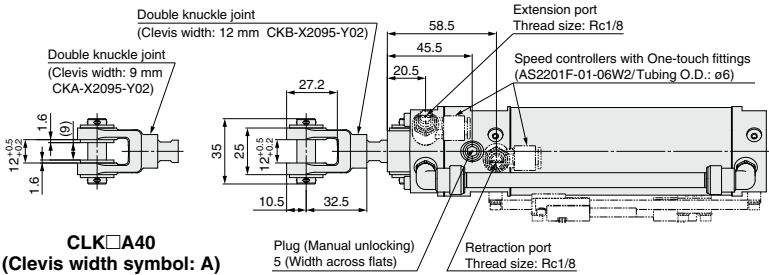

CLK□A40
(Clevis width symbol: A)

CLK□B40
(Clevis width symbol: B)

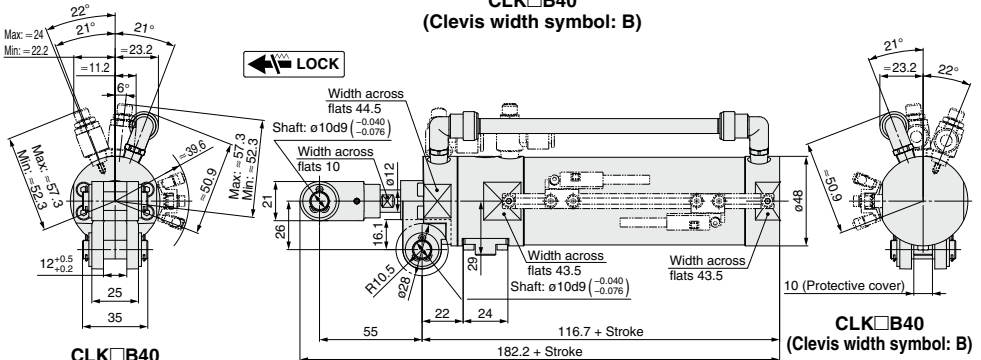

CLK□B40
(Clevis width symbol: B)

CLK□B40
(Clevis width symbol: B)

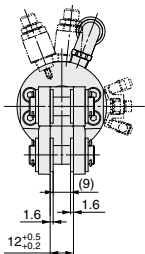

CLK□A40
(Clevis width symbol: A)

Pin (For Clevis/Double Knuckle Joint)

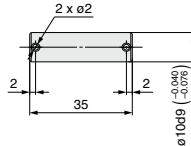

Part no.	Applicable cylinder
CKA-X2095-P02	CK□A25 to 40 series CLK□A25 to 40 series
CKB-X2095-P02	CK□B25 to 40 series CLK□B25 to 40 series

* Cotter pins and flat washers are provided as a standard.

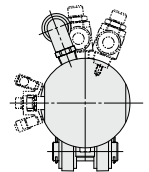

CLK□A40
(Clevis width symbol: A)

C(L)KG/C(L)KP-X2095 Series Auto Switch Mounting

Auto Switch Proper Mounting Position (Detection at Stroke End) and Its Mounting Height

D-P3DWA□□

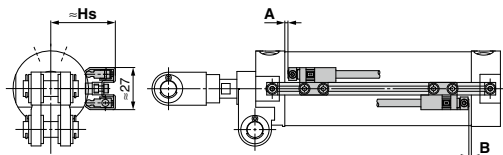

D-P4DW□□

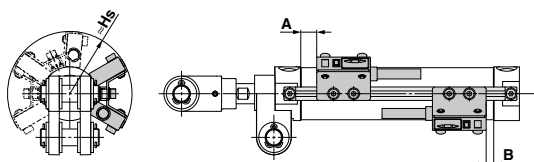

D-P79W

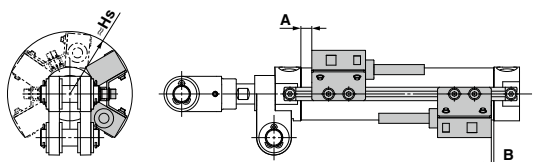

D-P7□□□□

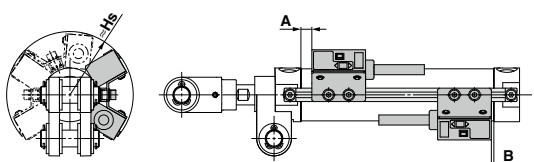

Auto Switch Mounting Position and Its Height Unit: mm

Applicable auto switch	Symbol	Auto switch set value and its height		
		ø25	ø32	ø40
D-P3DWA□□	A	10.5	10.5	11.5
	B	8	9	11
	Hs	30.5	34	39.5
D-P4DW□□	A	8	8	9
	B	5.5	6.5	8.5
	Hs	37.1	40.7	45.4
D-P79W	A	6	5	6
	B	2	4	5.5
	Hs	37.7	40.8	45.1
D-P7□□□□	A	6	5	6
	B	2	4	5.5
	Hs	37.3	40.2	45.1

Note 1) The mounting position should be referred for reference only for the auto switch mounting position at the stroke end detection. Adjust the auto switch after confirming the operation to set actual.

Note 2) A/B dimensions are the distance from the standard position (above drawing) to the end surface of the auto switch.

Note 3) The auto switch mounting position is temporarily set at the time of shipping from our factory. Change it to the desired position in accordance to your facility.

Note 4) Adjust the auto switch after confirming the operating conditions in the actual setting.

Minimum Stroke for Auto Switch Mounting

Unit: mm

Applicable auto switch	1 pc.	2 pcs.
D-P3DWA□□	50	50
D-P4DW□□	50	50
D-P7□□□□	50	50

Operating Range

Unit: mm

Applicable auto switch	Bore size		
	ø25	ø32	ø40
D-P3DWA□□	6	5.5	5.5
D-P4DW□□	5	5	5
D-P7□□□□	8	7.5	8.5

Other than the applicable auto switches listed in "How to Order," the following auto switches are mountable.

*For magnetic field resistant 2-color indicator solid state auto switches, auto switches with pre-wired connector (D-P4DW□□DPC type) are also available.

Please order the auto switch and mounting brackets detailed below separately from the cylinder.

Auto switch part no.	Auto switch mounting bracket part no.	
	ø25	ø32, ø40
D-M9□/D-M9□V	—	Note 2) ①BQ-1 ②BQ2-012
D-M9□W/D-M9□WV		
D-A9□/D-A9□V	—	Note 2) ①BQ-1 ②BQ2-012

Note 1) Only suitable for CKG□ types.

Note 2) Two types of auto switch mounting brackets are used as a set. The screws (M2.5 x 4 L) built into the auto switch are not used.

Note 3) ø25 is available through a special order of D-A9□/D-A9□V.

C(L)KG/C(L)KP-X2095 Series

How to Mount and Move the Auto Switch

■ D-P3DWA□□

- Remove either of two hexagon socket head cap screws that secure the auto switch mounting rail. Since the spacer is installed between the cylinder body and auto switch mounting rail, be careful not to drop the spacer.
- Insert the auto switch mounting bracket B (nut) into the groove on the auto switch mounting rail.
- Tighten the hexagon socket head cap screw you have removed in step ① and fix the auto switch mounting rail.
- Remove the hexagon socket head cap screw A (M2.5) attached to the auto switch. Mount the auto switch mounting bracket (pressed stainless steel bracket) on the auto switch and tighten the hexagon socket head cap screw A (M2.5) you have removed 3 to 4 turns to temporarily mount the bracket.
- Put the hexagon socket head cap screw B (M3) through the holes in the flange (round holes at 2 locations) of the auto switch mounting bracket (pressed stainless steel bracket) and screw them into the M3 tapped parts of the auto switch mounting bracket B (nut), and tighten them 3 to 4 turns to temporarily mount the auto switch.
- After checking the detection position, tighten the hexagon socket head cap screws A and B in order. Tighten the hexagon socket head cap screw B evenly.

Auto Switch Mounting Bracket Part No. for C(L)KG□-X2095 series (Including bracket, screw)

Applicable cylinder	Applicable bore size		
	24	32	40
CKG□-X2095	BK5-025S		
CLKG□-X2095	BK5-025S		

■ D-P4DW□□

- Attach the auto switch to the auto switch mounting bracket C, using a hexagon socket head cap screw (M3 x 12 L).
(The tightening torque is 0.5 to 0.8 N·m.)
- Fix the auto switch mounting bracket B and the auto switch mounting bracket C temporarily by tightening the hexagon socket head cap screw (M3 x 6 L).
- Insert the temporarily tightened auto switch mounting bracket B into the mating groove of the auto switch rail, and slide the auto switch onto the auto switch rail through the groove.
- Check the detecting position of the auto switch and fix the auto switch firmly with the hexagon socket head cap screw (M3 x 6 L, M3 x 12 L).
(The tightening torque is 0.5 to 0.8 N·m.)
- If the detecting position is changed, go back to step ③.

Applicable auto switch: D-P4DWL/Z, D-P4DWSC, D-P4DWSE

Bore size	Auto switch mounting bracket part no.	Contents	Qty.
ø25 ø32 ø40	BK4-025	Auto switch mounting bracket B	1
		Auto switch mounting bracket C	1
		Hexagon socket head cap screw (M3 x 6 L, with SW + PW)	2
		Hexagon socket head cap screw (M3 x 12 L)	2

■ D-P7□, D-P79WSE

- Attach the auto switch to the auto switch mounting bracket C, using a hexagon socket head cap screw (M3 x 15 L).
(The tightening torque is 0.5 to 0.8 N·m.)
- Fix the auto switch mounting bracket B and the auto switch mounting bracket C temporarily by tightening the hexagon socket head cap screw (M3 x 6 L).
- Insert the temporarily tightened auto switch mounting bracket B into the mating groove of the auto switch rail, and slide the auto switch onto the auto switch rail through the groove.
- Check the detecting position of the auto switch and fix the auto switch firmly with the hexagon socket head cap screw (M3 x 6 L, M3 x 15 L).
(The tightening torque is 0.5 to 0.8 N·m.)
- If the detecting position is changed, go back to step ③.

*Be aware that D-P79WSE should be installed in the specified direction shown when installed to the auto switch mounting bracket C. Be sure to mount it so that the soft resin mold surface is in contact with the auto switch mounting bracket C.

Applicable auto switch: D-P74, D-P74-376, D-P74GSC, D-P79WSE

Bore size	Auto switch mounting bracket part no.	Contents	Qty.
ø25 ø32 ø40	BK2-025	Auto switch mounting bracket B	1
		Auto switch mounting bracket C	1
		Hexagon socket head cap screw (M3 x 6 L, with SW + PW)	2
		Hexagon socket head cap screw (M3 x 15 L)	2

- Modification of the detection position should be made in the condition of ⑤.
Note 1) The tightening torque for a hexagon socket head cap screw (M2.5) is 0.2 to 0.3 N·m. Hold the shorter side of a hexagon wrench, and turn it to tighten. (Too much tightening may break the switch)
Note 2) The tightening torque for a hexagon socket head cap screw (M3) is 0.5 to 0.7 N·m.

(Attached to auto switch)
Hexagon socket head cap screw A (M2.5 x 11 L)

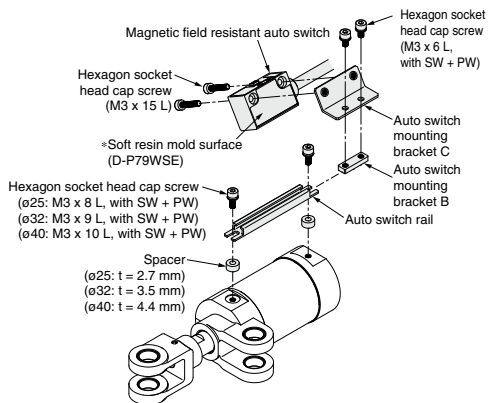
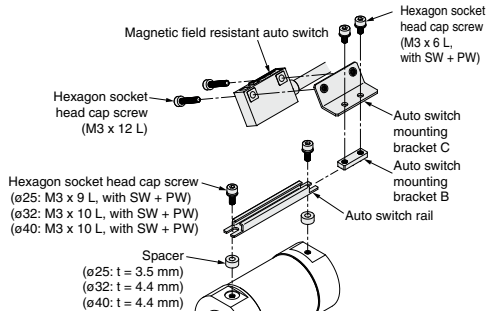
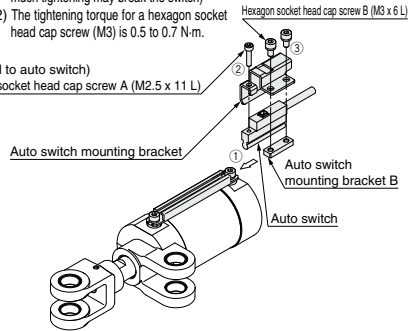

Auto Switch Rail Assembly Part No.

Applicable cylinder series	Bore size	Applicable stroke	Auto switch rail assembly part no.
CKG CLKG	ø25	50	CKG25-X2095-R050
		75	CKG25-X2095-R075
		100	CKG25-X2095-R100
		125	CKG25-X2095-R125
		150	CKG25-X2095-R150
	ø32	50	CKG32-X2095-R050
		75	CKG32-X2095-R075
		100	CKG32-X2095-R100
CKG CKP CLKG CLKP	ø32	125	CKG32-X2095-R125
		150	CKG32-X2095-R150
		50	CKG40-X2095-R050
	ø40	75	CKG40-X2095-R075
		100	CKG40-X2095-R100
		125	CKG40-X2095-R125
		150	CKG40-X2095-R150

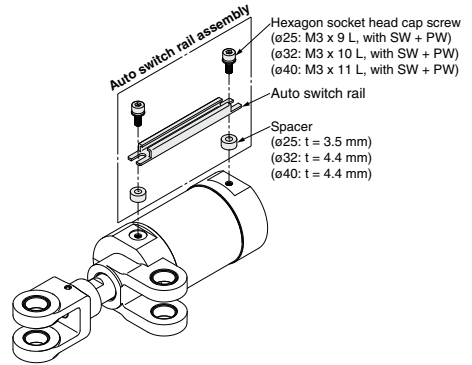

Applicable cylinder series	Bore size	Applicable stroke	Auto switch rail assembly part no.
CKP CLKP	ø25	50	CKP25-X2095-R050
		75	CKP25-X2095-R075
		100	CKP25-X2095-R100
		125	CKP25-X2095-R125
		150	CKP25-X2095-R150
	ø32	50	CKP32-X2095-R050
		75	CKP32-X2095-R075
		100	CKP32-X2095-R100
		125	CKP32-X2095-R125
		150	CKP32-X2095-R150

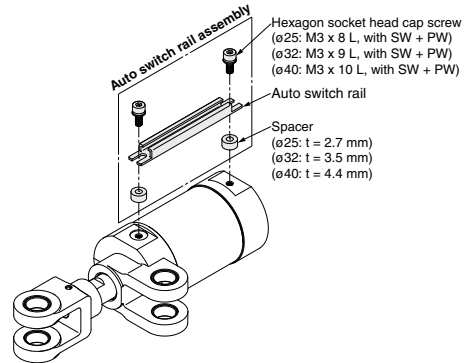



1 Unlock-port Separate Piping Type

Built-in standard magnet type with AC magnetic field resistant auto switch

CLKG **B** **32** - **50** **Y** **S** - **B** - **P3DWASC** **□** - **X1604**

Built-in strong magnet type with magnetic field resistant auto switch

CLKP **B** **32** - **50** **Y** **S** - **B** - **P79WSE** **□** - **X1604**

Clevis width

A	9 mm
B	12 mm

* Clevis width symbol

For A: Clevis width B (12 mm) plus two 1.6 mm washers, making the clevis width 9 mm.
Accessories in the form of pins/flat washers (4 pcs.)/cotter pins (2 pcs.) are included (but not assembled).

For B: Accessories in the form of pins/flat washers (2 pcs.)/cotter pins (2 pcs.) are included (but not assembled).

Bore size

25	25 mm
32	32 mm
40	40 mm

Cylinder stroke

Bore size	Standard stroke
ø25 to ø40	50, 75, 100, 125, 150

End bracket

Y	Double knuckle joint
----------	----------------------

* Clevis width symbol

For A: Clevis width B (12 mm) plus two 1.6 mm washers, making the clevis width 9 mm.
Accessories in the form of pins/flat washers (4 pcs.)/cotter pins (2 pcs.) are included (but not assembled).

For B: Accessories in the form of pins/flat washers (2 pcs.)/cotter pins (2 pcs.) are included (but not assembled).

Option

Nil	None
S	With speed controller

* Speed controllers (2 pcs.) are shipped together (but not assembled).

Locking direction

B	Retraction locking
F	Extension locking

Number of auto switches

Nil	2 pcs.
S	1 pc.
n	"n" pcs. (n = 3, 4, 5...n)

Unlock-port Separate Piping Type

Auto switch

For applicable auto switch model, refer to the **Table 1**.

Nil	Without auto switch (built-in magnet) Without switch mounting rail
P	Without auto switch (built-in magnet) With switch mounting rail

* Auto switch rails are shipped assembled.

* Auto switches are shipped together (but not assembled).

* Auto switch rails are shipped with mounting locations attached on the right side, as you look from the rod end.

Built-in Standard (Strong) Magnet Cylinder Part No.

- Built-in standard (strong) magnet type without auto switch and switch mounting rail
Symbol for the auto switch type is "Nil" as shown below.
CLKG: (Example) CLKGA32-50Y-B-X1604
CLKP: (Example) CLKPA32-50Y-B-X1604
- Built-in standard (strong) magnet type without auto switch, with switch mounting rail
Symbol for the auto switch type is "P" as shown below.
CLKG: (Example) CLKGA32-50Y-B-P-X1604
CLKP: (Example) CLKPA32-50Y-B-P-X1604

Table 1

Applicable Magnetic Field Resistant Auto Switches/Refer to pages 1341 to 1435 for detailed auto switch specifications.

Applicable cylinder series	Type	Auto switch model	Applicable magnetic field	Electrical entry	Indicator light	Wiring (Pin no. in use)	Load voltage	Lead wire length	Applicable load		
CLKG series	Solid state auto switch	P3DWASC	AC magnetic field (Single-phase AC welding magnetic field)	Pre-wired connector	2-color indicator	2-wire (3-4)	24 VDC	0.3 m	Relay, PLC (Note 1)		
		P3DWASE				2-wire (1-4)					
		P3DWA		Grommet		2-wire		0.5 m			
		P3DWAL								Pre-wired connector	2-wire (3-4)
		P3DWAZ		Grommet	2-wire	5 m					
		P4DWSC						Pre-wired connector		2-wire (1-4)	0.3 m
		P4DWSE		Grommet	2-wire	3 m					
		P4DWL						Pre-wired connector		2-wire	5 m
P4DWZ	Grommet	2-wire	0.3 m								
CLKP series				Reed auto switch	P79WSE	DC/AC magnetic field	Pre-wired connector	2-color indicator	2-wire (1-4)	24 VDC	0.3 m
	P74-376	2-wire (3-4)									
	P74GSC	Grommet	2-wire		3 m						
	P74L						Pre-wired connector	2-wire	100 VAC		
	P74Z										Grommet

Note 1) PLC: Programmable Logic Controller

Note 2) There are other applicable auto switches other than the listed above. For details, refer to page 505

Note 3) Refer to page 506 and 507 when ordering the auto switch mounting bracket assembly or switch mounting rail assembly.

Dimensions

CLKG□/CLKP□25
Extension locking (B)

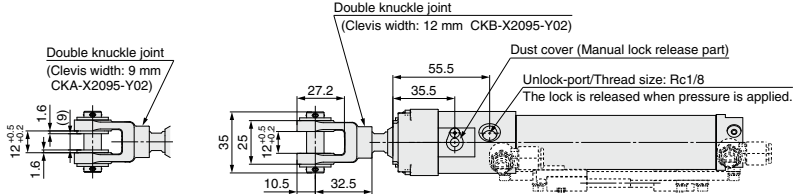

CLK□A25
(Clevis width symbol: A)

CLK□B25
(Clevis width symbol: B)

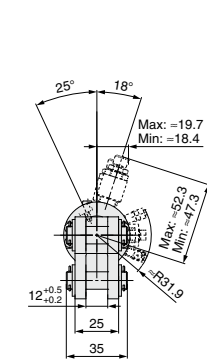

CLK□B25
(Clevis width symbol: B)

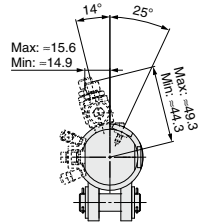
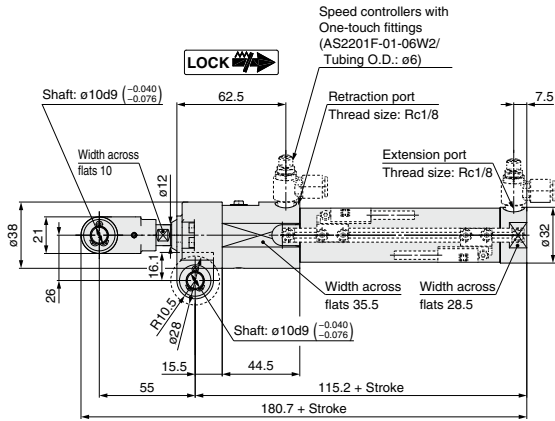

CLK□B25
(Clevis width symbol: B)

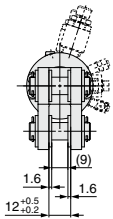

CLK□A25
(Clevis width symbol: A)

Pin (For Clevis/Double Knuckle Joint)

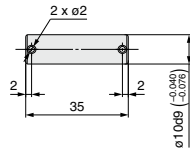

Part no.	Applicable cylinder
CKA-X2095-P02	CK□A25 to 40 series CLK□A25 to 40 series
CKB-X2095-P02	CK□B25 to 40 series CLK□B25 to 40 series

* Cotter pins and flat washers are provided as a standard.

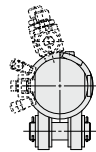

CLK□A25
(Clevis width symbol: A)

CLKG/CLKP Series

Made to Order Specifications

Please contact SMC for detailed dimensions, specifications and lead times.



1 Unlock-port Separate Piping Type

Dimensions

CLKG□/CLKP□32, 40 Retraction locking (B)

Double knuckle joint
(Clevis width: 9 mm CKA-X2095-Y02)

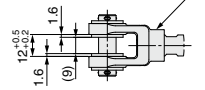

CLK□A32, 40
(Clevis width symbol: A)

Double knuckle joint
(Clevis width: 12 mm
CKB-X2095-Y02)

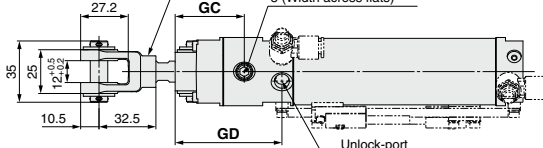

CLK□B32, 40
(Clevis width symbol: B)

Speed controllers with
One-touch fittings
(AS2201F-01-06W2/
Tubing O.D.: ø6)

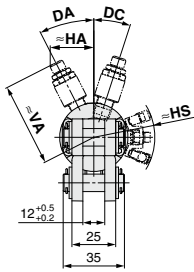

CLK□B32, 40
(Clevis width symbol: B)

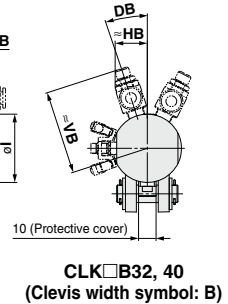
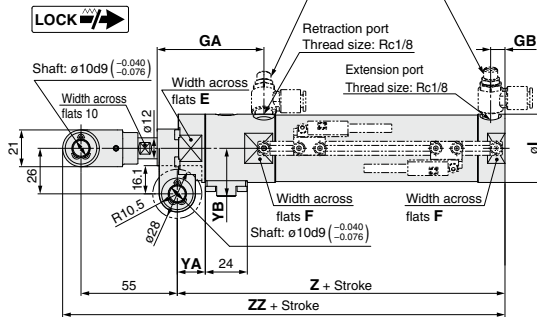

CLK□B32, 40
(Clevis width symbol: B)

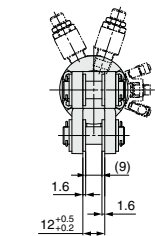

CLK□A32, 40
(Clevis width symbol: A)

Pin (For Clevis/Double Knuckle Joint)

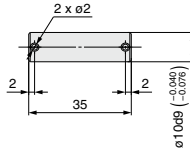

Part no.	Applicable cylinder
CKA-X2095-P02	CK□A25 to 40 series CLK□A25 to 40 series
CKB-X2095-P02	CK□B25 to 40 series CLK□B25 to 40 series

* Cotter pins and flat washers are provided as a standard.

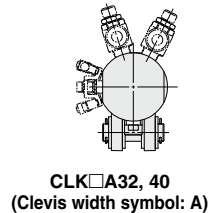

CLK□A32, 40
(Clevis width symbol: A)

Symbol	DA	DB	DC	E	F	GA	GB	GC	GD	HA		HB		HS	øI	VA		VB		YA	YB	Z	ZZ
										MAX.	MIN.	MAX.	MIN.			MAX.	MIN.	MAX.	MIN.				
32	27°	18°	18°	36	35	61	8.2	39.5	61	27.2	24.9	19.5	18.3	35.7	39	52.8	47.8	52.8	47.8	16	27.5	112.2	177.7
40	22°	21°	21°	44.5	43.5	58	11	44.5	58.5	24.9	23	24	22.2	39.6	48	57.3	52.3	57.3	52.3	21	29	116.7	182.2

CLKG/CLKP Series

Made to Order Specifications

Please contact SMC for detailed dimensions, specifications and lead times.



1 Unlock-port Separate Piping Type

Dimensions

CLKG□/CLKP□32 Extension locking (F)

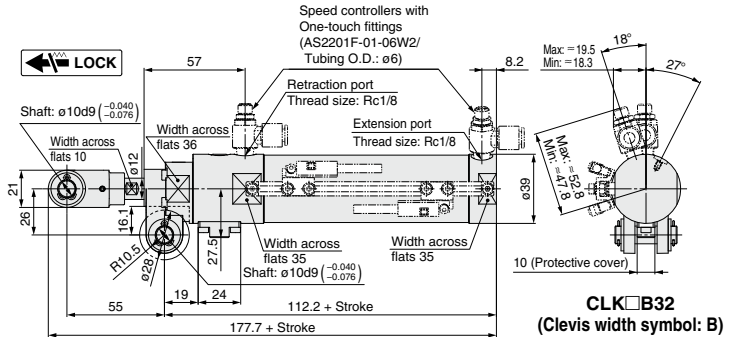
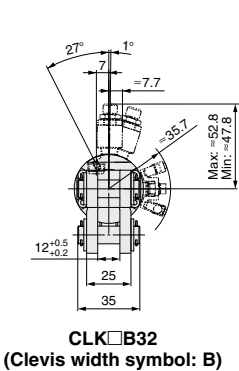
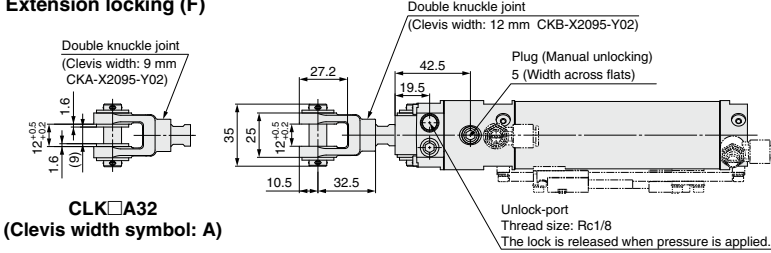

Pin (For Clevis/Double Knuckle Joint)

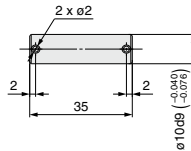

Part no.	Applicable cylinder
CKA-X2095-P02	CK□A25 to 40 series CLK□A25 to 40 series
CKB-X2095-P02	CK□B25 to 40 series CLK□B25 to 40 series

* Cotter pins and flat washers are provided as a standard.

